



# HP ZBook 15 Mobile Workstation

Maintenance and Service Guide

**IMPORTANT!** This document is intended for  
HP authorized service providers only.

© Copyright 2013 Hewlett-Packard  
Development Company, L.P.

Bluetooth is a trademark owned by its proprietor and used by Hewlett-Packard Company under license. Intel and Core are U.S. registered trademarks of Intel Corporation. Microsoft and Windows are U.S. registered trademarks of Microsoft Corporation. SD Logo is a trademark of its proprietor.

The information contained herein is subject to change without notice. The only warranties for HP products and services are set forth in the express warranty statements accompanying such products and services. Nothing herein should be construed as constituting an additional warranty. HP shall not be liable for technical or editorial errors or omissions contained herein.

First Edition: August 2013

Document Part number: 721768-001

### **Product notice**

This guide describes features that are common to most models. Some features may not be available on your computer.

Not all features are available in all editions of Windows 8. This computer may require upgraded and/or separately purchased hardware, drivers, and/or software to take full advantage of Windows 8 functionality. See <http://www.microsoft.com> for details.

### **Software terms**

By installing, copying, downloading, or otherwise using any software product preinstalled on this computer, you agree to be bound by the terms of the HP End User License Agreement (EULA). If you do not accept these license terms, your sole remedy is to return the entire unused product (hardware and software) within 14 days for a refund subject to the refund policy of your place of purchase.

For any further information or to request a full refund of the computer, please contact your local point of sale (the seller).

## Safety warning notice

---

 **WARNING!** To reduce the possibility of heat-related injuries or of overheating the computer, do not place the computer directly on your lap or obstruct the computer air vents. Use the computer only on a hard, flat surface. Do not allow another hard surface, such as an adjoining optional printer, or a soft surface, such as pillows or rugs or clothing, to block airflow. Also, do not allow the AC adapter to contact the skin or a soft surface, such as pillows or rugs or clothing, during operation. The computer and the AC adapter comply with the user-accessible surface temperature limits defined by the International Standard for Safety of Information Technology Equipment (IEC 60950).

---



---

# Table of contents

<b>1 Product description .....</b>	<b>1</b>
<b>2 External component identification .....</b>	<b>8</b>
Display .....	8
Buttons, speakers, and fingerprint reader (select models only) .....	10
Keys .....	12
Lights .....	13
TouchPad .....	14
Front .....	15
Left side .....	16
Right side .....	17
Rear .....	18
Bottom .....	19
<b>3 Illustrated parts catalog .....</b>	<b>21</b>
Service tag .....	21
Computer major components .....	23
LED display assembly subcomponents .....	30
Bracket Kit .....	31
Cable Kit .....	32
Plastics Kit .....	33
Mass storage devices .....	34
Miscellaneous parts .....	35
Sequential part number listing .....	37
<b>4 Removal and replacement procedures preliminary requirements .....</b>	<b>44</b>
Tools required .....	44
Service considerations .....	44
Plastic parts .....	44
Cables and connectors .....	45
Drive handling .....	45

Grounding guidelines .....	46
Electrostatic discharge damage .....	46
Packaging and transporting guidelines .....	47
Workstation guidelines .....	47
<b>5 Removal and replacement procedures for Customer Self-Repair parts .....</b>	<b>49</b>
Component replacement procedures .....	49
Battery .....	50
Service cover .....	51
Hard drive .....	52
Optical drive .....	54
WWAN module .....	56
Solid-state drive .....	58
WLAN module .....	59
Primary memory module .....	61
Keyboard .....	62
Expansion memory module .....	67
<b>6 Removal and replacement procedures for Authorized Service Provider parts .....</b>	<b>69</b>
Component replacement procedures .....	69
RTC battery .....	69
Top cover .....	71
Fingerprint reader board .....	75
Function button board .....	77
Power button board .....	79
ExpressCard assembly .....	81
Smart card reader .....	83
Audio/USB board .....	85
USB board .....	87
Speakers .....	89
Fan/heat sink assembly .....	90
Processor .....	93
Graphics board .....	94
Display assembly .....	96
System board .....	103
Power connector cable .....	107
RJ-45 (network) cable .....	109
<b>7 Computer Setup .....</b>	<b>112</b>
Windows 8 — Computer Setup (BIOS), MultiBoot, and System Diagnostics .....	112

Using Computer Setup .....	112
Starting Computer Setup .....	112
Navigating and selecting in Computer Setup .....	113
Restoring default settings in Computer Setup .....	114
Updating the BIOS .....	114
Determining the BIOS version .....	114
Downloading a BIOS update .....	115
Using MultiBoot .....	116
About the boot device order .....	116
Choosing MultiBoot preferences .....	116
Setting a new boot order in Computer Setup .....	116
Dynamically choosing a boot device using the f9 prompt .....	117
Setting a MultiBoot Express prompt .....	117
Entering MultiBoot Express preferences .....	118
Using System Diagnostics .....	118
Windows 7 — Computer Setup (BIOS), MultiBoot, and HP PC Hardware Diagnostics (UEFI) .....	119
Using Computer Setup .....	119
Starting Computer Setup .....	119
Navigating and selecting in Computer Setup .....	119
Restoring default settings in Computer Setup .....	120
Updating the BIOS .....	121
Determining the BIOS version .....	121
Downloading a BIOS update .....	121
Using MultiBoot .....	122
About the boot device order .....	122
Choosing MultiBoot preferences .....	123
Setting a new boot order in Computer Setup .....	123
Dynamically choosing a boot device using the f9 prompt .....	123
Setting a MultiBoot Express prompt .....	124
Entering MultiBoot Express preferences .....	124
Using HP PC Hardware Diagnostics (UEFI) (select models only) .....	125
Downloading HP PC Hardware Diagnostics (UEFI) to a USB device .....	125
<b>8 Specifications .....</b>	<b>126</b>
Computer specifications .....	126
Hard drive specifications .....	127
Hard drive specifications (continued) .....	128
<b>9 Backup and recovery .....</b>	<b>129</b>
Windows 8 .....	129
Backing up your information .....	129

Performing a system recovery .....	130
Using the Windows recovery tools .....	131
Using f11 recovery tools .....	132
Using Windows 8 operating system media (purchased separately) .....	132
Using Windows Refresh for quick and easy recovery .....	133
Remove everything and reinstall Windows .....	133
Using HP Software Setup .....	134
Windows 7 .....	135
Creating recovery media and backups .....	135
Guidelines .....	135
Creating recovery media with HP Recovery Disc Creator .....	136
Creating recovery media .....	136
Backing up your information .....	136
Performing a system recovery .....	137
Using the Windows recovery tools .....	138
Using f11 recovery tools (select models only) .....	139
Using Windows 7 operating system media .....	139
<b>10 Statement of Volatility .....</b>	<b>141</b>
Non-volatile memory usage .....	143
Questions and answers .....	145
<b>11 Power cord set requirements .....</b>	<b>146</b>
Requirements for all countries .....	146
Requirements for specific countries and regions .....	146
<b>12 Recycling .....</b>	<b>148</b>
<b>Index .....</b>	<b>149</b>



# 1 Product description

Category	Description
<b>Product Name</b>	HP ZBook 15 Mobile Workstation
<b>Processors</b>	<ul style="list-style-type: none"><li>• Intel® Quad Core® i7-4900MQ 2.80-GHz (SC turbo up to 3.80-GHz) processor (1600-MHz front-side bus (FSB), 8.0-MB L3 cache, 47 W)</li><li>• Intel Quad Core i7-4800MQ 2.70-GHz (SC turbo up to 3.70-GHz) processor (1600-MHz FSB, 6.0-MB L3 cache, 47 W)</li><li>• Intel Quad Core i7-4700MQ 2.40-GHz (SC turbo up to 3.40-GHz) processor (1600-MHz FSB, 6.0-MB L3 cache, 47 W)</li><li>• Intel Quad Core i7-4600M 2.90-GHz (SC turbo up to 3.60-GHz) processor (1600-MHz FSB, 4.0-MB L3 cache, 37 W)</li><li>• Intel Dual Core i5-4330M 2.80-GHz (SC turbo up to 3.50-GHz) processor (1600-MHz FSB, 3.0-MB L3 cache, 37 W)</li><li>• Intel Dual Core i5-4300M 2.60-GHz (SC turbo up to 3.30-GHz) processor (1600-MHz FSB, 3.0-MB L3 cache, 37 W)</li></ul>
<b>Chipset</b>	Mobile Intel QM87
<b>Graphics</b>	<p><b>Switchable graphics:</b></p> <ul style="list-style-type: none"><li>• NVIDIA® Quadro® K2100M NVIDIA N15P-Q3 with 2-GB GDDR5 graphics subsystem memory (128-MB×16, 1.35-V, 1500-MHz, qty 8, 128-bit, FBW)</li><li>• NVIDIA Quadro K1100M NVIDIA N15P-Q1 with 2-GB GDDR5 graphics subsystem memory (128-MB×16, 1.35-V, 1400-MHz, qty 8, 128-bit, FBW)</li><li>• NVIDIA Quadro K610M NVIDIA N15M-Q2 with 1-GB GDDR5 graphics subsystem memory (128-MB×16, 1.35-V, 1300-MHz, qty 4, 64-bit, FBW)</li></ul> <p>Support for hybrid (switchable) graphics</p> <p>Support for open GL</p> <p>Support for DisplayPort 1.2</p> <p>Support for up to 4 total displays (through APR)</p> <p>Support for NVIDIA Mosaic Technology</p>

Category	Description
<b>Panel</b>	<ul style="list-style-type: none"> <li>15.6-in, full-high definition (FHD), AntiGlare (AG), RGB, light-emitting diode (LED), UWVA (1920×1080 resolution, 210 nits, 109% CG), DreamColor (7.2-mm, wedge design, eDP panel) with camera, not available with WWAN capability</li> <li>15.6-in, FHD, AG, RGB, LED, UWVA, DreamColor, without camera, not available with WWAN capability</li> <li>15.6-in, FHD, AG, LED, UWVA (1920×1080 resolution, 300 nits, 72% CG slim), non-DreamColor (3.8-mm flat design, eDP panel) with camera</li> <li>15.6-in, FHD, AG, LED, UWVA, non-DreamColor without camera</li> <li>15.6-in, FHD, AG, LED, SVA with camera</li> <li>15.6-in, FHD, AG, LED, SVA without camera</li> </ul> <p>All panels are 16:9 aspect ratio</p>
<b>Memory</b>	<p>Four customer-accessible/upgradable memory module slots</p> <p>Support for DDR3L 1600-MHz PC3-12800 dual channel memory</p> <p>Support for 8192-MB of system RAM in the following configurations:</p> <ul style="list-style-type: none"> <li>32768-MB total system memory (8192-MB×4)</li> <li>16384-MB total system memory (8192-MB×2 or 4096-MB×4)</li> <li>8192-MB total system memory (8192-MB×1 or 4096-MB×2)</li> <li>4096-MB total system memory (4096-MB×1)</li> </ul>
<b>Flash cache</b>	<p>32-GB MLC mSATA module (Intel Smart Response Technology (SRT))</p> <p>Dedicated MiniCard slot</p> <p>Support for no flash cache option</p> <p>Fast Flash Standby not supported</p> <p>Not available on computer models equipped with a solid-state drive (SSD) or a self-encrypted drive (SED)</p> <p>Not available on computer models equipped with the Linux operating system</p>
<b>MiniCard solid-state drive</b>	<p>128-GB mSATA SSD</p> <p>Not available if 32-GB flash cache is selected</p> <p>SSD is set as primary storage if selected; hard drive becomes secondary storage</p>

Category	Description
<b>Hard drive</b>	<p>Support for 6.35-cm (2.5-in) hard drives in 7.0-mm (.28-in) and 9.5-mm (.37-in) thickness</p> <p>Support for Serial ATA</p> <p>Support for 3D DriveGuard hard drive protection</p> <p>Support toolless removal</p> <p>Support for the following hard drives:</p> <ul style="list-style-type: none"> <li>• 1-TB, 5400-rpm, 9.5-mm</li> <li>• 750-GB, 7200-rpm, 7.0-mm</li> <li>• 500-GB, 7200-rpm, 7.0-mm</li> <li>• 500-GB, 5400-rpm, 7.0-mm, FIPS (not available on computer models equipped with the Windows 8, Windows 7, or Windows 8 downgrade operating systems)</li> <li>• 500-GB, 7200-rpm, 7.0-mm, self-encrypting drive (not available on computer models equipped with the Windows 8, Windows 7, or Windows 8 downgrade operating systems)</li> <li>• 320-GB, 7200-rpm, 7.0-mm</li> </ul> <p>Support for the following 6.35-cm (2.5-in) solid-state drives:</p> <ul style="list-style-type: none"> <li>• 512-GB SATA-3 SSD</li> <li>• 256-GB SATA-3 self-encrypting SSD (not available on computer models equipped with the Windows 8, Windows 7, or Windows 8 downgrade operating systems)</li> <li>• 180-GB SATA-3 SSD</li> <li>• 128-GB SATA-3 SSD</li> </ul>
<b>Upgrade drive</b>	<p>Support for the following 9.5-mm (.37-in) , SATA optical drives:</p> <ul style="list-style-type: none"> <li>• Blu-ray R/RE DVD±RW SuperMulti Double-Layer Drive</li> <li>• Blu-ray ROM DVD±RW SuperMulti Double-Layer Drive</li> <li>• DVD±RW SuperMulti Double-Layer Drive</li> <li>• DVD-ROM Drive</li> </ul> <p>Support for 6.35-cm (2.5-in) 750-GB, 7200-rpm SATA hard drive in 7.0-mm (.28-in) and 9.5-mm (.37-in) thicknesses</p> <p>Support for the following 6.35-cm (2.5-in) SATA III solid-state drives:</p> <ul style="list-style-type: none"> <li>• 512-GB SSD</li> <li>• 256-GB SED SSD (not available on computer models equipped with the Windows 8, Windows 7, or Windows 8 downgrade operating systems)</li> </ul> <p>Supports for no Upgrade drive option (bezel)</p>

<b>Category</b>	<b>Description</b>
<b>Audio and video</b>	<p>Stereo speakers</p> <p>Dual array microphone</p> <p>HD Audio with DTS Studio sound</p> <p>DTS sound+</p> <p>Integrated HD 720p webcam (fixed [no tilt], activity LED, 1280×720 by 30 frames per second)</p> <p>Support for no webcam option</p>
<b>Ethernet</b>	<p>Intel I217-LM 10/100/1000 Ethernet, with Intel I217-LM Gigabit Network Connection</p> <p>Support for Power Optimizer</p> <p>Intel Stable Image Platform Program (SIPP)</p>
<b>Wireless</b>	<p>Integrated wireless local area network (WLAN) options by way of wireless module</p> <p>Two WLAN antennas built into display assembly</p> <p>Support for the following WLAN formats:</p> <ul style="list-style-type: none"> <li>• Intel Centrino Advanced-N 6205 Combo Adapter</li> <li>• Intel Centrino Advanced-N 6235 Combo Adapter</li> <li>• Intel Dual Band Wireless-AC 7260 802.11 ac 2x2 WiFi + BT 4.0 Combo Adapter</li> </ul> <p>Integrated wireless wide area network (WWAN) options by way of wireless module (select models only)</p> <p>Two WWAN antennas built into display assembly</p> <p>Security provided by subscriber identify module (SIM), slot located in battery bay</p> <p>Support for the following WWAN formats:</p> <ul style="list-style-type: none"> <li>• HP hs3110 HSPA+ Mobile Broadband Module</li> <li>• HP lt4111 LTE/EV-DO/HSPA+ Mobile Broadband Module</li> <li>• HP lt4112 LTE/HSPA+ Mobile Broadband Module</li> </ul>
<b>External media cards</b>	<p>HP 2-in-1 multiformat Digital Media Reader Slot with push-push technology. Reads data from and writes data to digital memory cards such as Secure Digital (SD).</p>

Category	Description
<b>Ports</b>	<ul style="list-style-type: none"> <li>• AC adapter, HP Smart</li> <li>• Audio-in (mono microphone)/audio-out (stereo headphone) combo jack</li> <li>• Battery (secondary)</li> <li>• DisplayPort 1.2</li> <li>• Docking</li> <li>• RJ45 (Ethernet)</li> <li>• Thunderbolt</li> <li>• USB 3.0 (2)</li> <li>• USB 3.0 charging (1)</li> <li>• USB: 2.0 (1)</li> <li>• VGA (Dsub 15 pin) supporting: 1920×1200 external resolution @ 75 Hz, hot plug and unplug and autodetection for correct output to wide-aspect vs. standard aspect video</li> </ul>
<b>Keyboard/pointing devices</b>	<p>Full-size, island-style, backlit (and non-backlit) keyboard with numeric keypad</p> <p>Gesture support: MultiTouch gestures enabled, two-finger scrolling, and pinch-zoom as default</p> <p>Support for Windows 8 dual-point (pointing stick with 3 pointing stick buttons plus TouchPad with 3 TouchPad buttons)</p> <p>DuraKeys</p> <p>Spill Resistant with drain</p> <p>TouchPad requirements:</p> <ul style="list-style-type: none"> <li>• On/off button</li> <li>• Glass with chemical etched surface (DuraPad)</li> <li>• Support for 2-way scroll</li> <li>• Taps enabled by default</li> <li>• Gestures enabled by default: <ul style="list-style-type: none"> <li>◦ 2-finger scrolling</li> <li>◦ 2-finger zoom (pinch)</li> </ul> </li> <li>• Image sensor TouchPad</li> </ul>
<b>Power requirements</b>	<p>Support for the following AC adapters:</p> <ul style="list-style-type: none"> <li>• 200-W, HP Smart Adapter, slim</li> <li>• 150-W, HP Smart Adapter, slim</li> <li>• 120-W, HP Smart Adapter, slim</li> </ul>

Category	Description
<b>Power requirements</b> <i>(continued)</i>	<p>Support for the following batteries</p> <ul style="list-style-type: none"> <li>• 9-cell, 100-WHr, 3.0-AHr, Li-ion battery</li> <li>• 9-cell, 73-WHr, 2.2-AHr, Li-ion battery</li> <li>• 8-cell, 83-WHr, 2.8-AHr, Li-ion battery</li> <li>• 8-cell, 75-WHr, 2.8-AHr, Li-ion battery</li> </ul>
<b>Security</b>	<p>Support security lock</p> <p>Trusted platform module (TPM) 1.2 (Infineon; soldered down) and TPM Enhanced Drive Lock (For the People's Republic of China and Asia Pacific countries and regions, disabled but available)</p> <p>Fingerprint reader</p> <p>Integrated smart card reader</p>
<b>Operating system</b>	<p><b>Preinstalled:</b></p> <ul style="list-style-type: none"> <li>• Windows 8 CH 64-bit (only available in the People's Republic of China with Hardware Kit)</li> <li>• Windows 8 EM 64-bit</li> <li>• Windows 8 ML 64-bit</li> <li>• Windows 8 Professional 64-bit</li> <li>• Windows 8 Professional 64-bit DPK with Windows 7 Professional 64-bit Image (not supported in the People's Republic of China)</li> <li>• Windows 7 Professional 64-bit</li> <li>• FreeDOS 2.0</li> <li>• SuSE Linux Enterprise (SLED 11) Service Pack 2, 64-bit (not available on computer models equipped with WWAN capability or a Blu-ray R/RE DVD±RW SuperMulti Double-Layer Drive or Blu-ray ROM DVD±RW SuperMulti Double-Layer Drive)</li> </ul> <p><b>Restore media-DRDVD:</b></p> <ul style="list-style-type: none"> <li>• DRDVD Windows 8 (available with any Windows 8 loc, required any Windows 8 Professional downgrade operating system)</li> <li>• DRDVD Windows 7 (available with any Windows 8 or Windows 7 Professional downgrade loc)</li> <li>• SRDVD SuSE Linux Enterprise (SLED) Service Pack 2, 64-bit (available with FreeDOS and SuSE Linux)</li> </ul>

Category	Description
<b>Operating system</b> <i>(continued)</i>	<p data-bbox="639 226 898 258"><b>Restore media-OSDVD:</b></p> <ul data-bbox="639 279 1471 604" style="list-style-type: none"> <li data-bbox="639 279 1018 310">• Windows 8 64-bit (for service only)</li> <li data-bbox="639 331 1174 363">• Windows 8 Country-Specific 64-bit (for service only)</li> <li data-bbox="639 384 1185 415">• Windows 8 Emerging Market 64-bit (for service only)</li> <li data-bbox="639 436 1409 499">• Windows 8 Professional 64-bit (only available and required with Windows 8 downgrade operating systems)</li> <li data-bbox="639 520 1430 604">• Windows 7 Professional 64-bit (available with any Windows 8 Professional or Windows 7 Professional downgrade loc, not available in the People's Republic of China)</li> </ul> <hr/> <p data-bbox="639 632 751 663"><b>Certified::</b></p> <ul data-bbox="639 684 1161 768" style="list-style-type: none"> <li data-bbox="639 684 847 716">• Microsoft WHCK</li> <li data-bbox="639 737 1161 768">• SuSE Linux Enterprise (SLED) Service Pack 2, 64-bit</li> </ul> <hr/> <p data-bbox="639 789 850 821"><b>Web-only support:</b></p> <ul data-bbox="639 842 1377 1241" style="list-style-type: none"> <li data-bbox="639 842 879 873">• Windows 8.1 64-bit</li> <li data-bbox="639 894 994 926">• Windows 8.1 Professional 64-bit</li> <li data-bbox="639 947 959 978">• Windows 7 Enterprise 64-bit</li> <li data-bbox="639 999 959 1031">• Windows 7 Enterprise 32-bit</li> <li data-bbox="639 1052 978 1083">• Windows 7 Professional 32-bit</li> <li data-bbox="639 1104 943 1136">• Windows 7 Ultimate 64-bit</li> <li data-bbox="639 1157 943 1188">• Windows 7 Ultimate 32-bit</li> <li data-bbox="639 1209 1377 1241">• SuSE Linux Enterprise (SLED) Service Pack 2, 64-bit (closed source drivers)</li> </ul>
<b>Serviceability</b>	<p data-bbox="639 1262 946 1293"><b>End user replaceable parts:</b></p> <ul data-bbox="639 1314 1150 1818" style="list-style-type: none"> <li data-bbox="639 1314 799 1346">• AC adapter</li> <li data-bbox="639 1367 834 1398">• Battery (system)</li> <li data-bbox="639 1419 791 1451">• Hard drive</li> <li data-bbox="639 1472 783 1503">• Keyboard</li> <li data-bbox="639 1524 1150 1556">• Memory modules (4, 2 expansion and 2 primary)</li> <li data-bbox="639 1577 802 1608">• mSATA SSD</li> <li data-bbox="639 1629 810 1661">• Optical drive</li> <li data-bbox="639 1682 727 1713">• SSD</li> <li data-bbox="639 1734 826 1766">• WLAN module</li> <li data-bbox="639 1787 842 1818">• WWAN module</li> </ul>

## 2 External component identification

### Display



Item	Component	Description
(1)	WLAN antennas (2, select models only)*	Send and receive wireless signals to communicate with a WLAN.
(2)	WWAN antennas (2, select models only)*	Send and receive wireless signals to communicate with a WWAN.
(3)	Internal microphones (2)	Record sound.
(4)	Webcamera light (select models only)	On: The webcam is in use.



Item	Component	Description
(5)	Webcamera (select models only)	<p>Records video and captures still photographs.</p> <p>For information on using the webcamera in Windows 8, access <b>HP Support Assistant</b>. To access HP Support Assistant on the Start screen, select the <b>HP Support Assistant</b> app.</p> <p>For information on using the webcamera in Windows 7, select <b>Start &gt; All Programs &gt; Communication and Chat &gt; HP WebCam</b>.</p>
(6)	Internal display switch	<p>Turns off the display or initiates Sleep if the display is closed while the power is on.</p> <p><b>NOTE:</b> The display switch is not visible on the outside of the computer.</p>

\*The antennas are not visible from the outside of the computer. For optimal transmission, keep the areas immediately around the antennas free from obstructions. To see wireless regulatory notices, see the section of the *Regulatory, Safety, and Environmental Notices* that applies to your country or region. To access this guide, from the Start screen, type `support`, select the **HP Support Assistant** app, select **My computer**, and then select **User guides**.

## Buttons, speakers, and fingerprint reader (select models only)

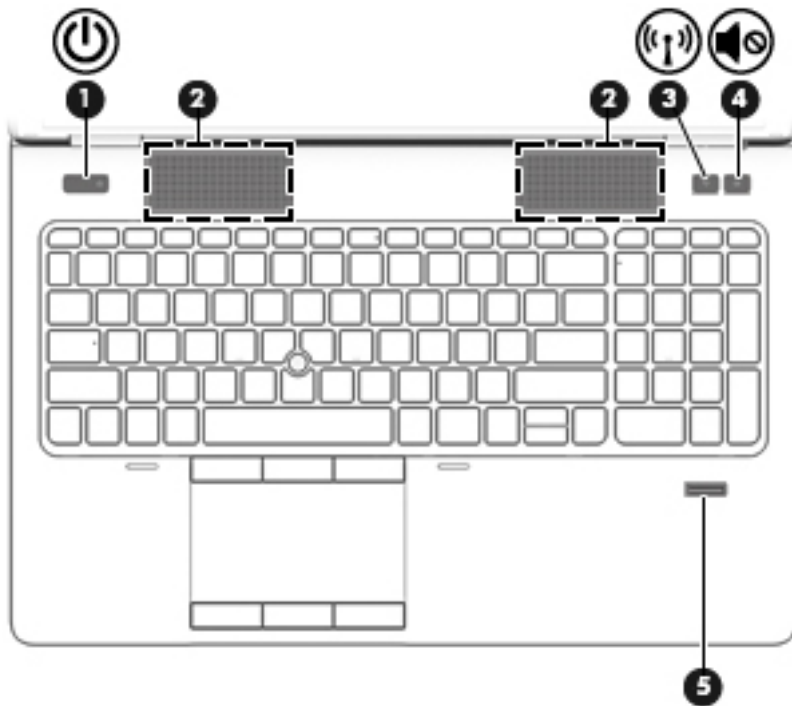

Item	Component	Description
(1)	Power button	<ul style="list-style-type: none"><li>• When the computer is off, press the button to turn on the computer.</li><li>• When the computer is on, press the button briefly to initiate Sleep.</li><li>• When the computer is in the Sleep state, press the button briefly to exit Sleep.</li><li>• When the computer is in Hibernation, press the button briefly to exit Hibernation.</li></ul> <p><b>CAUTION:</b> Pressing and holding down the power button will result in the loss of unsaved information.</p> <p>If the computer has stopped responding and Windows® shutdown procedures are ineffective, press and hold the power button for at least 5 seconds to turn off the computer.</p> <p>To learn more about your power settings, see your power options. From the Start screen, type <code>power</code>, select <b>Settings</b>, and then select <b>Power Options</b>.</p>

Item	Component	Description
(2)	Speakers (2)	Produce SRS Premium Sound or SRS Premium Sound PRO (select models only).  <b>NOTE:</b> To use the SRS Premium Sound software, from the Start screen, type <i>SRS</i> , and then select <b>SRS Pro Audio</b> .
(3)	Wireless button	Turns the wireless feature on or off but does not establish a wireless connection.
(4)	Volume mute button	Mutes and restores speaker sound.
(5)	Fingerprint reader (select models only)	Allows a fingerprint logon to Windows, instead of a password logon.

# Keys

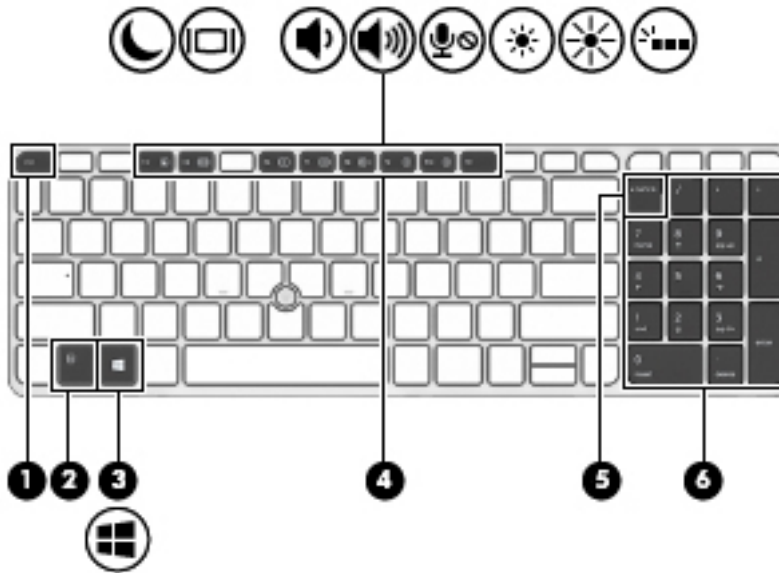

Item	Component	Description
(1)	esc key	Displays system information when pressed in combination with the <b>fn</b> key.
(2)	fn key	Executes frequently used system functions when pressed in combination with a function key, the <b>num lk</b> key, the <b>esc</b> key, or the <b>b</b> key.
(3)	Windows button	Returns you to the Start screen from an open app or the Windows desktop.  <b>NOTE:</b> Pressing the Windows button again will return you to the previous screen.
(4)	Function keys	Execute frequently used system functions when pressed in combination with the <b>fn</b> key.
(5)	num lk key	Alternates between the navigational and numeric functions on the integrated numeric keypad.
(6)	Integrated numeric keypad	When num lk has been enabled, it can be used like an external numeric keypad.

# Lights

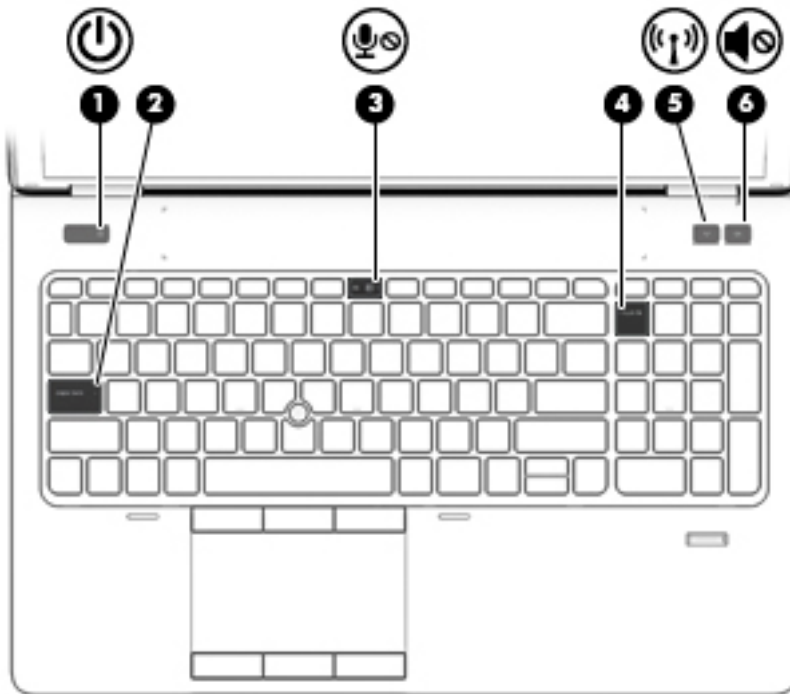

Item	Component	Description
(1)	Power light	<ul style="list-style-type: none"><li>On: The computer is on.</li><li>Blinking: The computer is in the Sleep state.</li><li>Off: The computer is off.</li></ul>
(2)	Caps lock light	On: Caps lock is on.
(3)	Microphone mute light	<ul style="list-style-type: none"><li>Amber: Microphone sound is off.</li><li>Off: Microphone sound is on.</li></ul>
(4)	Num lock light	On: Num lock is on.
(5)	Wireless light	<ul style="list-style-type: none"><li>White: An integrated wireless device, such as a WLAN device and/or a Bluetooth device, is on.</li><li>Amber: All wireless devices are off.</li></ul>
(6)	Mute light	<ul style="list-style-type: none"><li>Amber: Computer sound is off.</li><li>Off: Computer sound is on.</li></ul>

# TouchPad

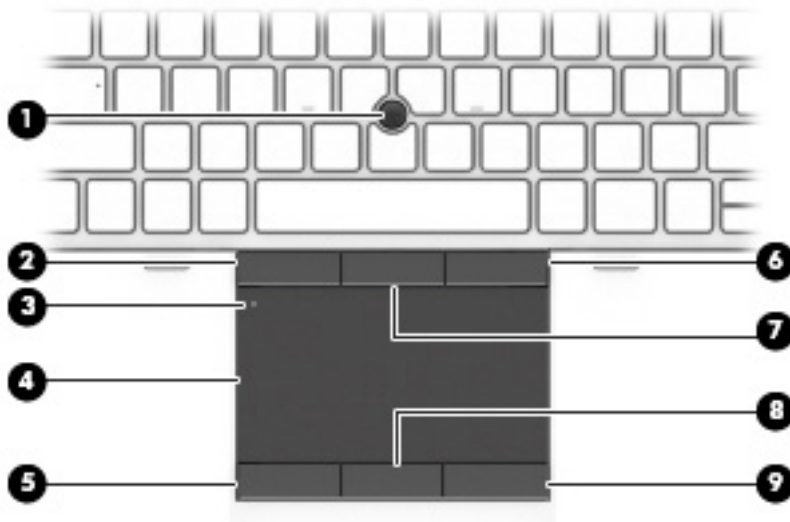

Item	Component	Description
(1)	Pointing stick	Moves the pointer and selects or activates items on the screen.
(2)	Left pointing stick button	Functions like the left button on an external mouse.
(3)	TouchPad on/off button	Turns the TouchPad on and off.
(4)	TouchPad zone	Moves the pointer and selects or activates items on the screen.
(5)	Left TouchPad button	Functions like the left button on an external mouse.
(6)	Right pointing stick button	Functions like the right button on an external mouse.
(7)	Center pointing stick button	Functions like the center button on an external mouse.
(8)	Center TouchPad button	Functions like the center button on an external mouse.
(9)	Right TouchPad button	Functions like the right button on an external mouse.

# Front



Item	Component	Description
(1)	Wireless light	<ul style="list-style-type: none"><li>• White: An integrated wireless device, such as a WLAN device and/or a Bluetooth device, is on.</li><li>• Amber: All wireless devices are off.</li></ul>
(2)	Power light	<ul style="list-style-type: none"><li>• On: The computer is on.</li><li>• Blinking: The computer is in the Sleep state.</li><li>• Off: The computer is off.</li></ul>
(3)	AC adapter/Battery light	<ul style="list-style-type: none"><li>• White: The computer is connected to external power and the battery is charged from 90 to 99 percent.</li><li>• Off: The battery is fully charged.</li></ul>
(4)	Hard drive light	<ul style="list-style-type: none"><li>• Blinking white: The hard drive is being accessed.</li><li>• Amber: HP 3D DriveGuard has temporarily parked the hard drive.</li></ul>

## Left side

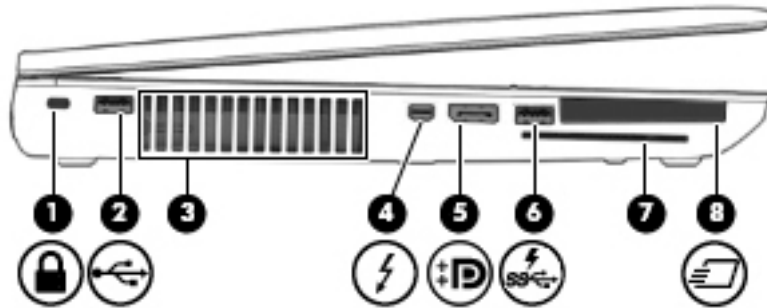

Item	Component	Description
		(7) Smart card reader Supports optional smart cards. (8) ExpressCard slot Supports optional ExpressCards.
(1)	Security cable slot	Attaches an optional security cable to the computer.  <b>NOTE:</b> The security cable is designed to act as a deterrent, but it may not prevent the computer from being mishandled or stolen.
(2)	USB 2.0 port	Connects an optional USB device.
(3)	Vent	Enables airflow to cool internal components.  <b>NOTE:</b> The computer fan starts up automatically to cool internal components and prevent overheating. It is normal for the internal fan to cycle on and off during routine operation.
(4)	Thunderbolt port	Connects an optional high-resolution display device or a high-performance data device.  <b>NOTE:</b> Thunderbolt is new technology. Install all the latest drivers for your Thunderbolt device before connecting the device to the Thunderbolt. Thunderbolt cable and Thunderbolt device (sold separately) must be compatible with Windows. To determine whether your device is Thunderbolt Certified for Windows, see <a href="https://thunderbolttechnology.net/products">https://thunderbolttechnology.net/products</a> .
(5)	Dual-Mode DisplayPort	Connects an optional digital display device, such as a high-performance monitor or projector.
(6)	USB 3.0 charging port	Connects optional USB 3.0 devices and provide enhanced USB power performance. The USB charging port can also charge select models of cell phones and MP3 players, even when the computer is off.
(7)	Smart card reader	Supports optional smart cards.
(8)	ExpressCard slot	Supports optional ExpressCards.



## Right side

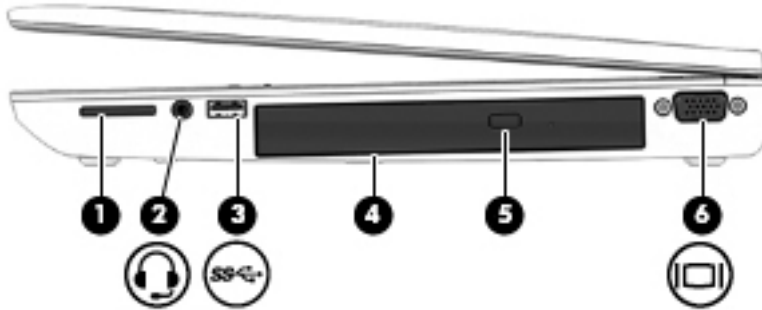

Item	Component	Description
(1)	Memory card reader	Reads data from and writes data to memory cards such as Secure Digital (SD).
(2)	Audio-out (headphone) jack/Audio-in (microphone) jack	<p>Connects optional powered stereo speakers, headphones, earbuds, a headset, or a television audio cable. Also connects an optional headset microphone. This jack does not support optional microphone-only devices.</p> <p><b>WARNING!</b> To reduce the risk of personal injury, adjust the volume before putting on headphones, earbuds, or a headset. For additional safety information, refer to the Regulatory, Safety, and Environmental Notices. To access this guide, from the Start screen, type <i>support</i>, select the <b>HP Support Assistant</b> app, select <b>My computer</b>, and then select <b>User guides</b>.</p> <p><b>NOTE:</b> When a device is connected to the jack, the computer speakers are disabled.</p> <p><b>NOTE:</b> Be sure that the device cable has a 4-conductor connector that supports both audio-out (headphone) and audio-in (microphone).</p>
(3)	USB 3.0 port	Connects an optional USB device.
(4)	Optical drive (select models only)	<p>Reads and writes, depending on your computer model, to an optical disc.</p> <p><b>NOTE:</b> For disc compatibility information, navigate to the Help and Support web page. Follow the web page instructions to select your computer model. Select <b>Support &amp; Drivers</b>, and then select <b>Product Information</b>.</p>
(5)	Optical drive eject button (select models only)	Releases the optical drive disc tray.
(6)	External monitor port	Connects an external VGA monitor or projector.

## Rear



Item	Component	Description
(1)	USB 3.0 port	Connects optional USB 3.0 devices and provides enhanced USB power performance.
(2)	Power connector	Connects an AC adapter.
(3)	AC adapter/Battery light	<ul style="list-style-type: none"><li>• White: The computer is connected to external power and the battery is charged from 90 to 99 percent.</li><li>• Off: The battery is fully charged.</li></ul>
(4)	RJ45 (network) jack	Connects a network cable.
	RJ45 (network) lights (2)	<ul style="list-style-type: none"><li>• Green (left): The network is connected.</li><li>• Amber (right): The network is showing activity.</li></ul>

## Bottom

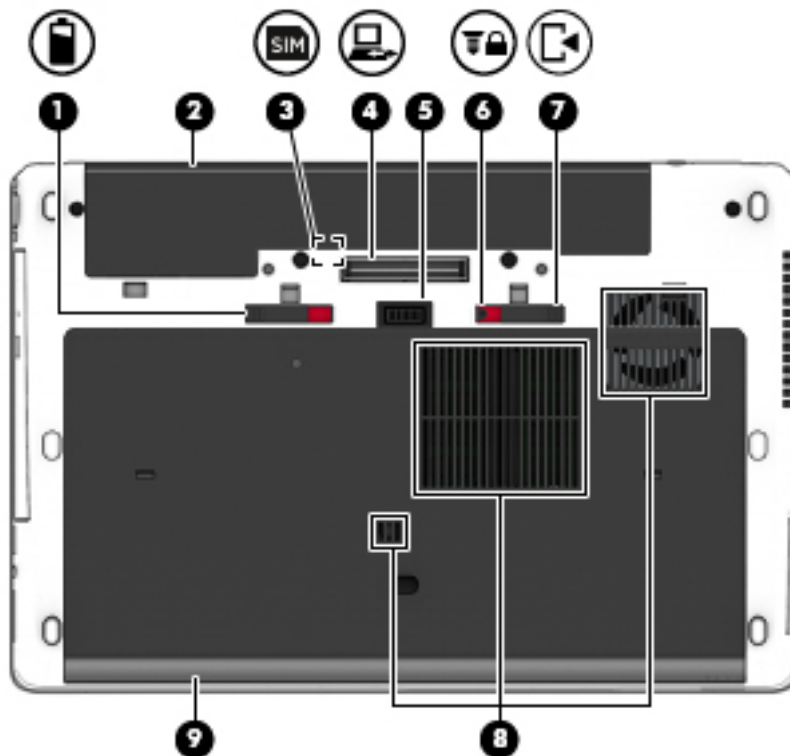

Item	Component	Description
(1)	Battery release latch	Releases the battery.
(2)	Battery bay	Holds the battery.
(3)	SIM slot	Supports a wireless subscriber identity module (SIM) (select models only). The SIM slot is located inside the battery bay.
(4)	Docking connector	Connects an optional docking device.
(5)	Accessory battery connector	Connects an optional accessory battery.
(6)	Service cover release lock	Locks the service cover.
(7)	Service cover release latch	Releases the service cover on the computer.

Item	Component	Description
<b>(8)</b>	Vents (3)	<p>Enable airflow to cool internal components.</p> <p><b>NOTE:</b> The computer fan starts up automatically to cool internal components and prevent overheating. It is normal for the internal fan to cycle on and off during routine operation.</p>
<b>(9)</b>	Service cover	<p>Provides access to the hard drive bay, the WLAN module slot, the WWAN module slot, and the memory module slots.</p> <p><b>CAUTION:</b> To prevent an unresponsive system, replace the wireless modules only with wireless modules authorized for use in the computer by the governmental agency that regulates wireless devices in your country or region. If you replace the modules and then receive a warning message, remove the modules to restore computer functionality, and then contact support through HP Support Assistant. To access HP Support Assistant from the Start screen, select the <b>HP Support Assistant</b> app.</p>

# 3 Illustrated parts catalog

## Service tag

When ordering parts or requesting information, provide the computer serial number and model number provided on the service tag.

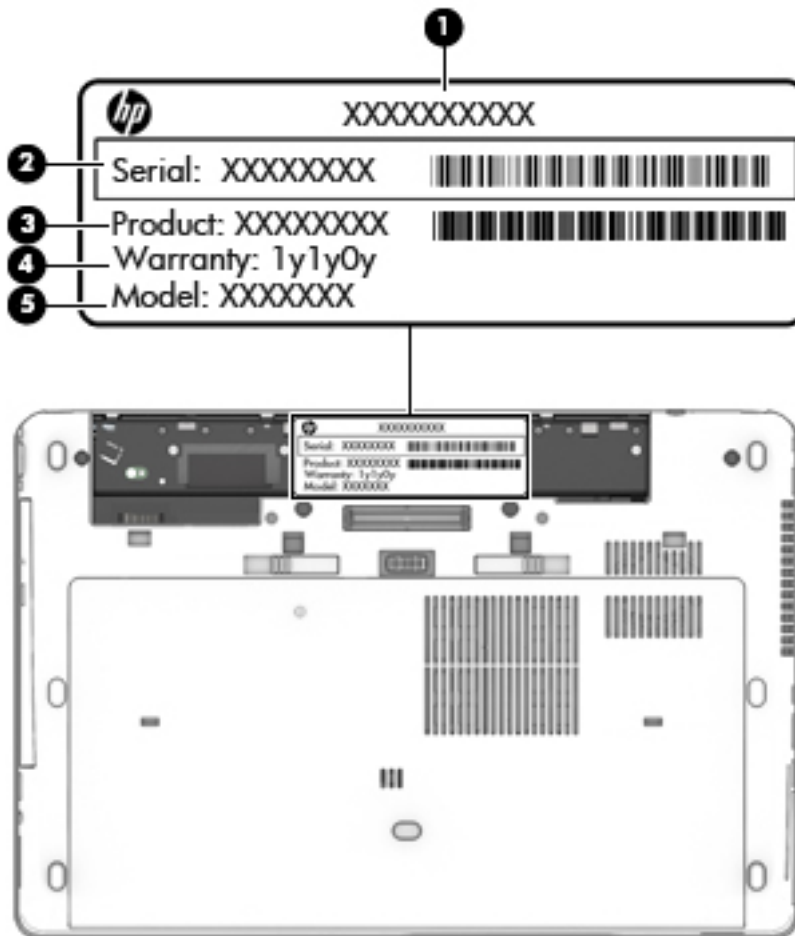

Item	Description	Function
(1)	Product name	This is the product name affixed to the front of the computer.

<b>Item</b>	<b>Description</b>	<b>Function</b>
<b>(2)</b>	Serial number (s/n)	This is an alphanumeric identifier that is unique to each product.
<b>(3)</b>	Part number/Product number (p/n)	This number provides specific information about the product's hardware components. The part number helps a service technician to determine what components and parts are needed.
<b>(4)</b>	Warranty period	This number describes the duration of the warranty period for the computer.
<b>(5)</b>	Model description	This is the alphanumeric identifier used to locate documents, drivers, and support for the computer.

# Computer major components

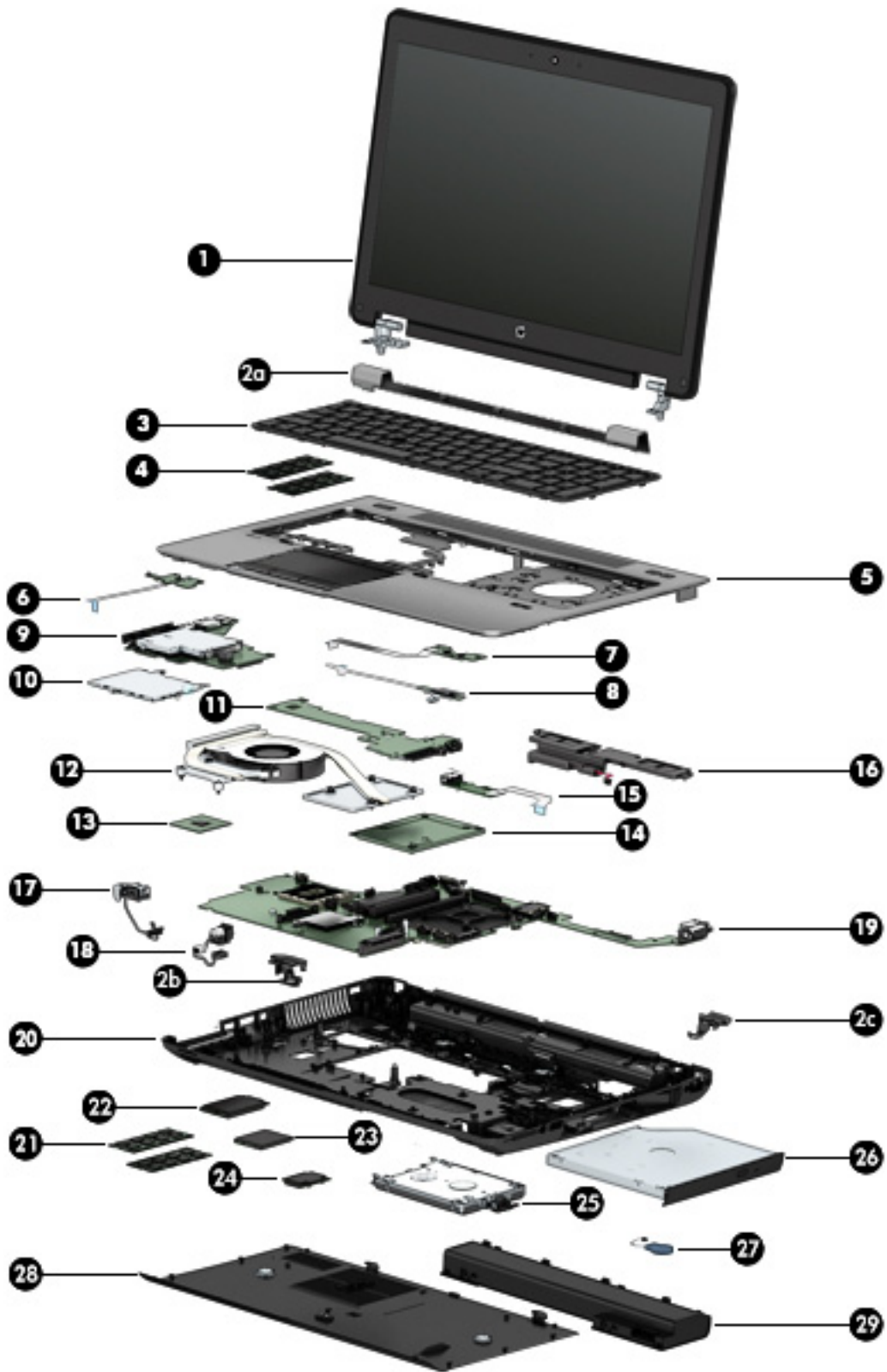

Item	Component	Spare part number
<b>(1)</b>	<b>Display assembly:</b> The DreamVision display assembly is spared as a whole unit assembly only. The LED display assembly is spared at the subcomponent level only. For more LED display assembly spare part information, see <a href="#">LED display assembly subcomponents on page 30</a> .	
	15.6-in, FHD, UWVA, DreamVision display assembly equipped with a webcam	735965-001
	15.6-in, FHD, UWVA, DreamVision display assembly not equipped with a webcam	735964-001
	<b>Hinge Cover Kit</b> , includes:	734294-001
<b>(2a)</b>	Hinge cover (includes HP logo)	
<b>(2b)</b>	Left-side rear corner cover	
<b>(2c)</b>	Right-side-side rear corner cover	
<b>(3)</b>	<b>Keyboard</b> (includes keyboard cable):	
	Keyboard with backlight and pointing stick (includes keyboard cable, backlight cable, and pointing stick cable):	
	For use in Belgium	733688-A41
	For use in Brazil	733688-201
	For use in Bulgaria	733688-261
	For use in Canada	733688-DB1
	For use in the Czech Republic and Slovakia	733688-FL1
	For use in Denmark	733688-081
	For use in France	733688-051
	For use in Germany	733688-041
	For use in Greece	733688-151
	For use in Hungary	733688-211
	For use in Iceland	733688-DD1
	For use in India	733688-D61
	For use in Israel	733688-BB1
	For use in Italy	733688-061
	For use in Japan	733688-291
	For use in Latin America	733688-161
	For use in the Netherlands	733688-B31
	For use in Northwest Africa	733688-FP1
	For use in Norway	733688-091
	For use in Portugal	733688-131
	For use in Romania	733688-271
	For use in Russia	733688-251



<b>Item</b>	<b>Component</b>	<b>Spare part number</b>
	For use in Saudi Arabia	733688-171
	For use in Slovenia	733688-BA1
	For use in South Korea	733688-AD1
	For use in Spain	733688-071
	For use in Sweden and Finland	733688-B71
	For use in Switzerland	733688-BG1
	For use in Taiwan	733688-AB1
	For use in Thailand	733688-281
	For use in Turkey	733688-141
	For use in the United Kingdom and Singapore	733688-031
	For use in the United States	733688-001
	Keyboard with pointing stick (includes keyboard cable and pointing stick cable):	
	For use in Belgium	745663-A41
	For use in Brazil	745663-201
	For use in Bulgaria	745663-261
	For use in Canada	745663-DB1
	For use in the Czech Republic and Slovakia	745663-FL1
	For use in Denmark	745663-081
	For use in France	745663-051
	For use in Germany	745663-041
	For use in Greece	745663-151
	For use in Hungary	745663-211
	For use in Iceland	745663-DD1
	For use in Israel	745663-BB1
	For use in Italy	745663-061
	For use in Japan	745663-291
	For use in Latin America	745663-161
	For use in the Netherlands	745663-B31
	For use in Northwest Africa	745663-FP1
	For use in Norway	745663-091
	For use in Portugal	745663-131
	For use in Romania	745663-271

<b>Item</b>	<b>Component</b>	<b>Spare part number</b>
	For use in Russia	745663-251
	For use in Saudi Arabia	745663-171
	For use in Slovenia	745663-BA1
	For use in South Korea	745663-AD1
	For use in Spain	745663-071
	For use in Sweden and Finland	745663-B71
	For use in Switzerland	745663-BG1
	For use in Taiwan	745663-AB1
	For use in Thailand	745663-281
	For use in Turkey	745663-141
	For use in the United Kingdom and Singapore	745663-031
	For use in the United States	745663-001
<b>(4)</b>	<b>Primary memory module</b> (PC3L, 12800, 1600-MHz):	
	8-GB	693374-001
	4-GB	691740-001
<b>(5)</b>	<b>Top cover</b> (includes TouchPad, TouchPad cable, and TouchPad bracket)	734281-001
<b>(6)</b>	<b>Power button board</b> (includes cable)	734285-001
<b>(7)</b>	<b>Function button board</b> (includes cable and double-sided adhesive)	734284-001
<b>(8)</b>	<b>Fingerprint reader board</b> (includes cable and double-sided adhesive)	734286-001
<b>(9)</b>	<b>ExpressCard assembly</b> (includes activity LEDs and Thunderbolt port, Dual Mode DisplayPort, and USB port)	734287-001
<b>(10)</b>	<b>Smart card reader</b> (includes cable)	742159-001
<b>(11)</b>	<b>Audio/USB board</b> (includes SD Card reader)	734288-001
<b>(12)</b>	<b>Fan/heat sink assembly</b> (includes replacement thermal material):	
	For use only with an NVIDIA Quadro K1100M NVIDIA N15P-Q1 graphics board, spare part number 734276-001	734289-001
	For use only with an NVIDIA Quadro K610M NVIDIA N15M-Q2 graphics board, spare part number 745325-001	734290-001
	For use only with an NVIDIA Quadro K2100M NVIDIA N15P-Q3 graphics board, spare part number 734277-001	734291-001
<b>(13)</b>	<b>Processor</b> (includes replacement thermal material):	
	Intel Quad Core i7-4900MQ 2.80-GHz (SC turbo up to 3.80-GHz) processor (1600-MHz FSB, 8.0-MB L3 cache, 47 W)	723523-002
	Intel Quad Core i7-4800MQ 2.70-GHz (SC turbo up to 3.70-GHz) processor (1600-MHz FSB, 6.0-MB L3 cache, 47 W)	723524-002

Item	Component	Spare part number
	Intel Quad Core i7-4700MQ 2.40-GHz (SC turbo up to 3.40-GHz) processor (1600-MHz FSB, 6.0-MB L3 cache, 47 W)	723521-002
	Intel Quad Core i7-4600M 2.90-GHz (SC turbo up to 3.60-GHz) processor (1600-MHz FSB, 4.0-MB L3 cache, 37 W)	737330-002
	Intel Dual Core i5-4330M 2.80-GHz (SC turbo up to 3.50-GHz) processor (1600-MHz FSB, 3.0-MB L3 cache, 37 W)	738201-002
	Intel Dual Core i5-4300M 2.60-GHz (SC turbo up to 3.30-GHz) processor (1600-MHz FSB, 3.0-MB L3 cache, 37 W)	738309-002
<b>(14)</b>	<b>Graphics board</b> (includes replacement thermal material):	
	NVIDIA Quadro K1100M NVIDIA N15P-Q1 graphics board	734276-001
	NVIDIA Quadro K610M NVIDIA N15M-Q2 graphics board	745325-001
	NVIDIA Quadro K2100M NVIDIA N15P-Q3 graphics board	734277-001
<b>(15)</b>	<b>USB board</b> (includes cable and double-sided adhesive)	734293-001
<b>(16)</b>	<b>Speakers</b> (include cable)	734292-001
<b>(17)</b>	<b>RJ-45 (network) cable</b> (included in the Cable Kit, spare part number 734283-001)	
<b>(18)</b>	<b>Power connector cable</b> (included in the Cable Kit, spare part number 734283-001)	
<b>(19)</b>	<b>System board</b> (includes battery connector bracket and replacement thermal material):	
	For use only on computer models equipped with an Intel Quad Core processor and the Windows 8 Professional operating system	734304-601
	For use only on computer models equipped with an Intel Quad Core processor and the Windows 8 Standard operating system	734304-501
	For use only on computer models equipped with an Intel Quad Core processor and the Linux operating system	734304-001
	For use only on computer models equipped with an Intel Dual Core processor and the Windows 8 Professional operating system	734303-601
	For use only on computer models equipped with an Intel Dual Core processor and the Windows 8 Standard operating system	734303-501
	For use only on computer models equipped with an Intel Dual Core processor and the Linux operating system	734303-001
<b>(20)</b>	<b>base enclosure</b> (includes 4 rubber feet, battery lock latch, battery release latch, and RJ-45 cover)	734279-001
<b>(21)</b>	<b>Expansion memory modules</b> (2, PC3L, 12800, 1600-MHz):	
	8-GB	693374-001
	4-GB	691740-001
<b>(22)</b>	<b>Solid-state drive</b> (SSD):	
	512-GB SATA-3 SSD	738714-001
	256-GB SATA-3 self-encrypting SSD	735598-001

<b>Item</b>	<b>Component</b>	<b>Spare part number</b>
	180-GB SATA-3 SSD	735597-001
	128-GB SATA-3 SSD	735596-001
	128-GB mSATA-3 SSD	735595-001
	32-GB mSATA flash cache SSD	735594-001
<b>(23)</b>	<b>WWAN module:</b>	
	HP hs3110 HSPA+ Mobile Broadband Module	723895-001
	HP lt4111 LTE/EV-DO/HSPA+ Mobile Broadband Module	704030-001
	HP lt4112 LTE/HSPA+ Mobile Broadband Module	704031-001
<b>(24)</b>	<b>WLAN module:</b>	
	Intel Centrino Advanced-N 6205 Combo Adapter	695915-001
	Intel Centrino Advanced-N 6235 Combo Adapter	670292-001
	Intel Dual Band Wireless-AC 7260 802.11 ac 2x2 WiFi + BT 4.0 Combo Adapter	710661-001
<b>(25)</b>	<b>Hard drive</b> (does not include hard drive bracket or screws):	
	1-TB, 5400-rpm, 9.5-mm	676521-001
	750-GB, 7200-rpm, 7.0-mm	633252-001
	500-GB, 7200-rpm, 7.0-mm	703267-001
	500-GB, 5400-rpm, 7.0-mm, FIPS	730946-001
	500-GB, 7200-rpm, 7.0-mm, self-encrypting	703268-001
	320-GB, 7200-rpm, 7.0-mm	634862-001
	<b>Hard Drive Hardware Kit</b> (not illustrated, includes hard drive bracket and screws)	734280-001
<b>(26)</b>	<b>Optical drive</b> (includes bezel and bracket):	
	Blu-ray R/RE DVD±RW SuperMulti Double-Layer Drive	735600-001
	Blu-ray ROM DVD±RW SuperMulti Double-Layer Drive	735599-001
	DVD±RW SuperMulti Double-Layer Drive	735602-001
	DVD-ROM Drive	735601-001
	Hard drive upgrade bay	734298-001
<b>(27)</b>	<b>RTC battery</b> (includes cable and double-sided adhesive)	734300-001
<b>(28)</b>	<b>Service cover</b>	734278-001
<b>(29)</b>	<b>Battery:</b>	
	9-cell, 100-WHr, 3.0-AHr, Li-ion battery	634087-001
	9-cell, 73-WHr, 2.2-AHr, Li-ion battery	634089-001

<b>Item</b>	<b>Component</b>	<b>Spare part number</b>
	8-cell, 83-WHr, 2.8-AHr, Li-ion battery	708456-001
	8-cell, 75-WHr, 2.8-AHr, Li-ion battery	708455-001

## LED display assembly subcomponents

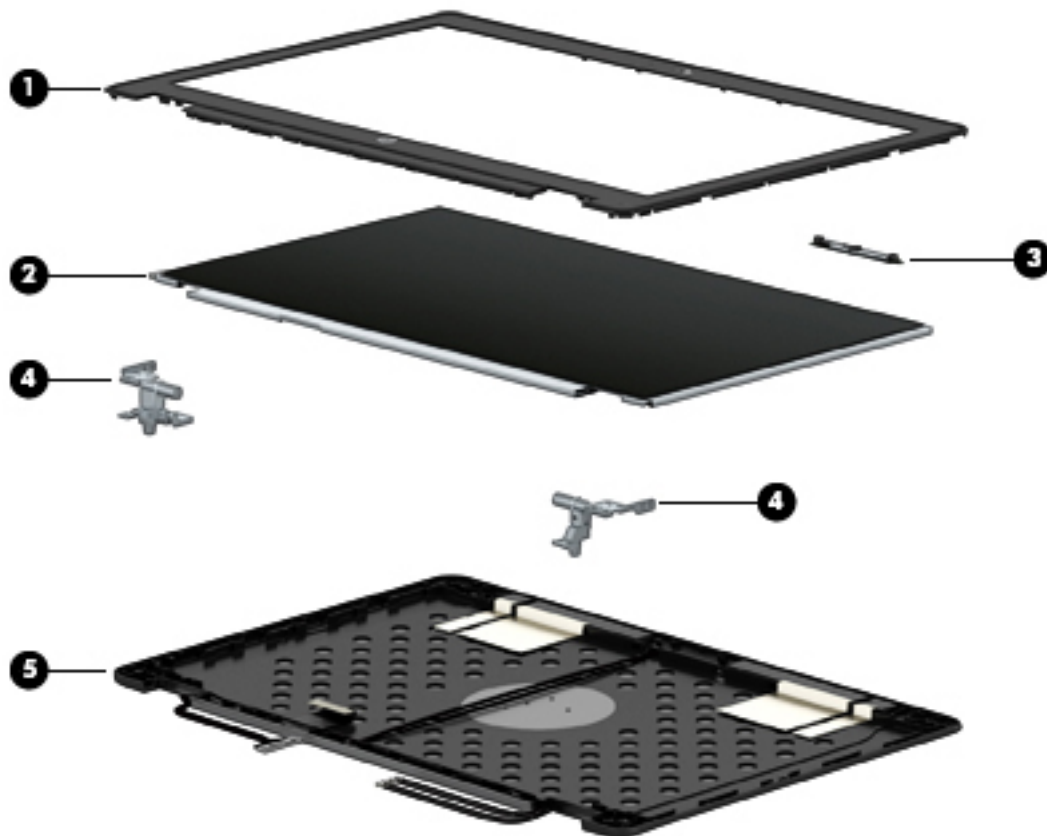

Item	Component	Spare part number
(1)	<b>Display bezel:</b>	
	For use only on computer models equipped with a webcam	734301-001
	For use only on computer models not equipped with a webcam	734302-001
(2)	<b>Display panel:</b>	
	15.6-in, FHD, UWVA, LED display panel	735607-001
	15.6-in, FHD, SVA, LED display panel	735604-001
(3)	<b>Webcam/microphone module</b> (includes double-sided adhesive)	734295-001
	<b>Microphone module</b> (includes double-sided adhesive)	735370-001
(4)	<b>Display hinges</b> (includes left and right hinges and display panel cable bracket)	738311-001
(5)	<b>Display Panel Support Kit</b> (includes display enclosure, display panel cable, and wireless antenna cables and transceivers)	734296-001

## Bracket Kit

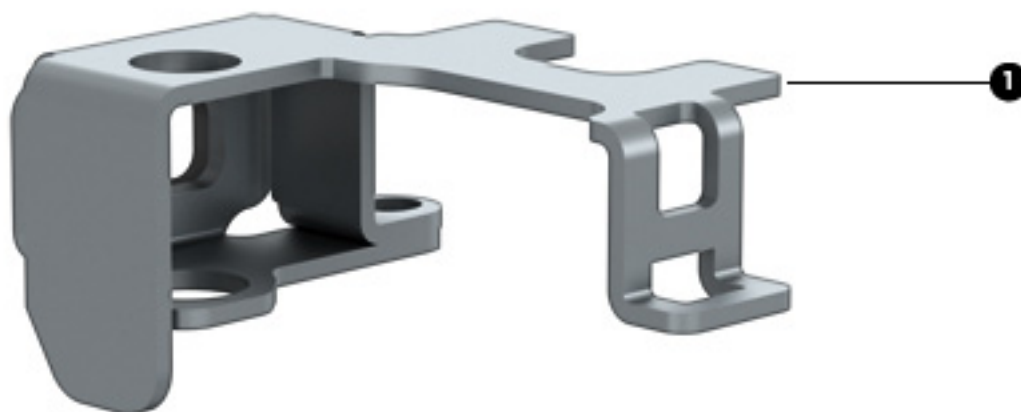

Item	Component	Spare part number
	<b>Bracket Kit</b> , includes:	734299-001
(1)	Security cable lock bracket	
(2)	Fingerprint reader board bracket	

# Cable Kit



Item	Component	Spare part number
	<b>Cable Kit</b> , includes:	734283-001
(1)	RJ-45 (network) cable	
(2)	Power connector cable	
	Replacement thermal material (not illustrated)	



# Plastics Kit

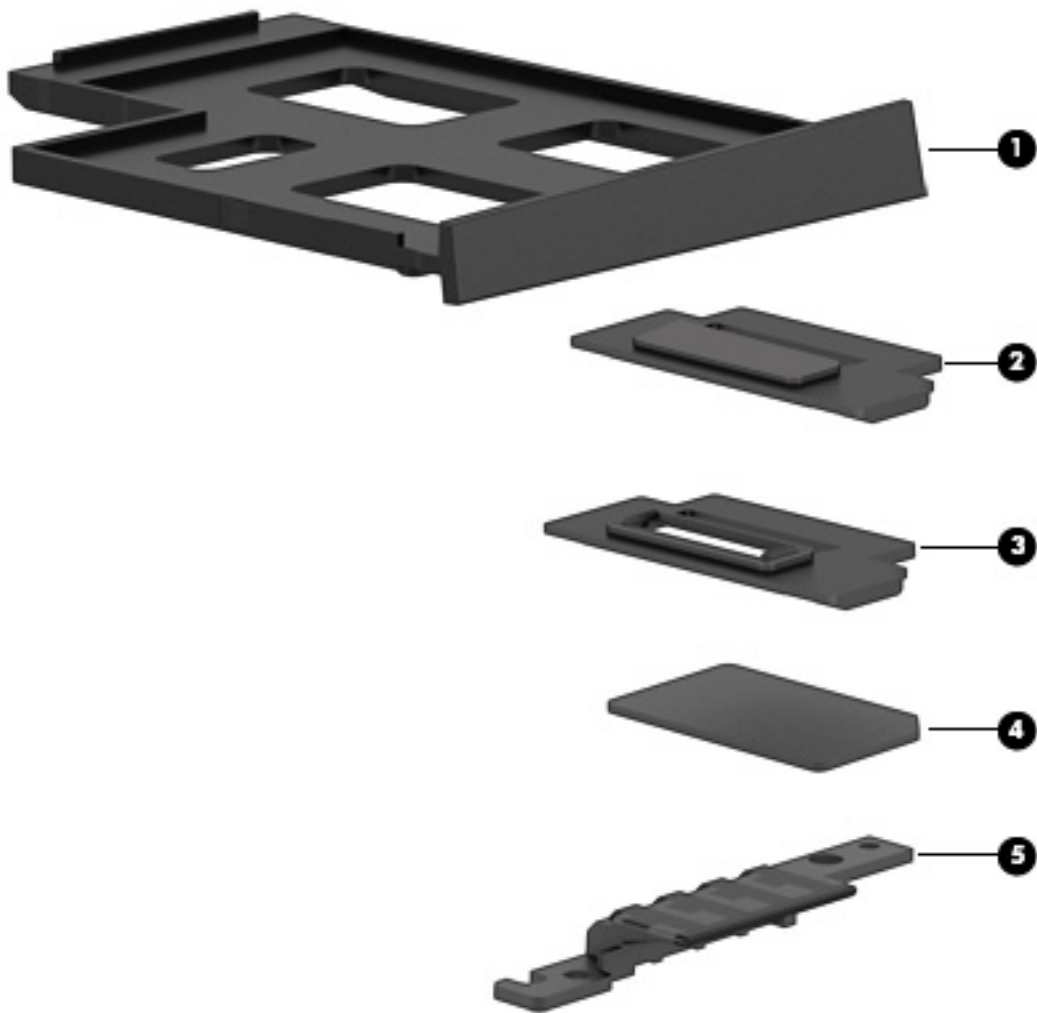

Item	Component	Spare part number
	<b>Plastics Kit</b> , includes:	734297-001
(1)	ExpressCard reader bezel	
(2)	Fingerprint reader blank cover	
(3)	Fingerprint reader bezel	
(4)	SD card reader bezel	
(5)	System lens	

# Mass storage devices



Item	Component	Spare part number
<b>(1)</b>	<b>Solid-state drive (SSD):</b>	
	512-GB SATA-3 SSD	738714-001
	256-GB SATA-3 self-encrypting SSD	735598-001
	180-GB SATA-3 SSD	735597-001
	128-GB SATA-3 SSD	735596-001
	128-GB mSATA-3 SSD	735595-001
	32-GB mSATA flash cache SSD	735594-001
	<b>Hard Drive Hardware Kit</b> , includes:	734280-001
<b>(2)</b>	Hard drive bracket	
	Screws (not illustrated)	
<b>(3)</b>	<b>Hard drive</b> (does not include hard drive bracket or screws):	
	1-TB, 5400-rpm, 9.5-mm	676521-001
	750-GB, 7200-rpm, 7.0-mm	633252-001
	500-GB, 7200-rpm, 7.0-mm	703267-001
	500-GB, 5400-rpm, 7.0-mm, FIPS	730946-001

Item	Component	Spare part number
	500-GB, 7200-rpm, 7.0-mm, self-encrypting	703268-001
	320-GB, 7200-rpm, 7.0-mm	634862-001
<b>(4)</b>	<b>Optical drive</b> (includes bezel and bracket):	
	Blu-ray R/RE DVD±RW SuperMulti Double-Layer Drive	735600-001
	Blu-ray ROM DVD±RW SuperMulti Double-Layer Drive	735599-001
	DVD±RW SuperMulti Double-Layer Drive	735602-001
	DVD-ROM Drive	735601-001
	Hard drive upgrade bay	734298-001

## Miscellaneous parts

Component	Spare part number
<b>AC adapter:</b>	
200-W HP Smart adapter (PFC, 3-wire, 4.5-mm)	693708-001
150-W HP Smart adapter (PFC, 3-wire, 4.5-mm)	693707-001
120-W HP Smart adapter (PFC, 3-wire, 4.5-mm)	693709-001
<b>Cable lock:</b>	
Docking station cable lock	575921-001
HP ultraslim keyed cable lock	703372-001
<b>HP professional slim top-load carrying case</b>	703888-001
<b>Mouse:</b>	
HP comfort grip wireless mouse	691922-001
HP USB laser mouse	674318-001
<b>Power cord</b> (3-pin, black, 1.83-m):	
For use in Argentina	490371-D01
For use in Australia	490371-011
For use in Brazil	490371-202
For use in Europe	490371-021
For use in India	490371-D61
For use in Israel	490371-BB1
For use in Italy	490371-061
For use in Japan	490371-291

<b>Component</b>	<b>Spare part number</b>
For use in North America	490371-001
For use in the People's Republic of China	490371-AA1
For use in South Africa	490371-AR1
For use in South Korea	490371-AD1
For use in Switzerland	490371-111
For use in Taiwan	490371-AB1
For use in Thailand	490371-201
For use in the United Kingdom and Singapore	490371-031
<b>Screw Kit</b>	734282-001

## Sequential part number listing

Spare part number	Description
490371-001	Power cord for use in North America (3-pin, black, 1.83-m)
490371-011	Power cord for use in Australia (3-pin, black, 1.83-m)
490371-021	Power cord for use in Europe (3-pin, black, 1.83-m)
490371-031	Power cord for use in the United Kingdom and Singapore (3-pin, black, 1.83-m)
490371-061	Power cord for use in Italy (3-pin, black, 1.83-m)
490371-111	Power cord for use in Switzerland (3-pin, black, 1.83-m)
490371-201	Power cord for use in Thailand (3-pin, black, 1.83-m)
490371-202	Power cord for use in Brazil (3-pin, black, 1.83-m)
490371-291	Power cord for use in Japan (3-pin, black, 1.83-m)
490371-AA1	Power cord for use in the People's Republic of China (3-pin, black, 1.83-m)
490371-AB1	Power cord for use in Taiwan (3-pin, black, 1.83-m)
490371-AD1	Power cord for use in South Korea (3-pin, black, 1.83-m)
490371-AR1	Power cord for use in South Africa (3-pin, black, 1.83-m)
490371-BB1	Power cord for use in Israel (3-pin, black, 1.83-m)
490371-D01	Power cord for use in Argentina (3-pin, black, 1.83-m)
490371-D61	Power cord for use in India (3-pin, black, 1.83-m)
575921-001	Docking station cable lock
633252-001	750-GB, 7200-rpm, SATA, 7.0-mm hard drive (does not include hard drive bracket or screws) <b>NOTE:</b> The hard drive bracket and screws are included in the Hard Drive Hardware Kit, spare part number 734280-001.
634087-001	9-cell, 100-WHr, 3.0-AHr, Li-ion battery
634089-001	9-cell, 73-WHr, 2.2-AHr, Li-ion battery
634862-001	320-GB, 7200-rpm, SATA, 7.0-mm hard drive (does not include hard drive bracket or screws) <b>NOTE:</b> The hard drive bracket and screws are included in the Hard Drive Hardware Kit, spare part number 734280-001.
670292-001	Intel Centrino Advanced-N 6235 Combo Adapter
674318-001	HP USB laser mouse
676521-001	1-TB, 5400-rpm, SATA, 9.5-mm hard drive (does not include hard drive bracket or screws) <b>NOTE:</b> The hard drive bracket and screws are included in the Hard Drive Hardware Kit, spare part number 734280-001.
691740-001	4-GB memory module (PC3L, 12800, 1600-MHz)
691922-001	HP comfort grip wireless mouse

Spare part number	Description
693374-001	8-GB memory module (PC3L, 12800, 1600-MHz)
693707-001	150-W HP Smart adapter (PFC, 3-wire, 4.5-mm)
693708-001	200-W HP Smart adapter (PFC, 3-wire, 4.5-mm)
693709-001	120-W HP Smart adapter (PFC, 3-wire, 4.5-mm)
695915-001	Intel Centrino Advanced-N 6205 Combo Adapter
703267-001	500-GB, 7200-rpm, SATA, 7.0-mm hard drive (does not include hard drive bracket or screws)  <b>NOTE:</b> The hard drive bracket and screws are included in the Hard Drive Hardware Kit, spare part number 734280-001.
703268-001	500-GB, 7200-rpm, SATA, 7.0-mm self-encrypting drive (SED, does not include hard drive bracket or screws)  <b>NOTE:</b> The hard drive bracket and screws are included in the Hard Drive Hardware Kit, spare part number 734280-001.
703372-001	HP ultraslim keyed cable lock
703888-001	HP professional slim top-load carrying case
704030-001	HP It4111 LTE/EV-DO/HSPA+ Mobile Broadband Module
704031-001	HP It4112 LTE/HSPA+ Mobile Broadband Module
708455-001	8-cell, 75-WHr, 2.8-AHr, Li-ion battery
708456-001	8-cell, 83-WHr, 2.8-AHr, Li-ion battery
710661-001	Intel Dual Band Wireless-AC 7260 802.11 ac 2x2 WiFi + BT 4.0 Combo Adapter
723521-002	Intel Quad Core i7-4700MQ 2.40-GHz (SC turbo up to 3.40-GHz) processor (1600-MHz FSB, 6.0-MB L3 cache, 47 W; includes replacement thermal material)
723523-002	Intel Quad Core i7-4900MQ 2.80-GHz (SC turbo up to 3.80-GHz) processor (1600-MHz FSB, 8.0-MB L3 cache, 47 W; includes replacement thermal material)
723524-002	Intel Quad Core i7-4800MQ 2.70-GHz (SC turbo up to 3.70-GHz) processor (1600-MHz FSB, 6.0-MB L3 cache, 47 W; includes replacement thermal material)
723895-001	HP hs3110 HSPA+ Mobile Broadband Module
730946-001	500-GB, 5400-rpm, SATA, 7.0-mm FIPS hard drive (does not include hard drive bracket or screws)  <b>NOTE:</b> The hard drive bracket and screws are included in the Hard Drive Hardware Kit, spare part number 734280-001.
733688-001	Keyboard with backlight and pointing stick for use in the United States (includes keyboard cable, backlight cable, and pointing stick cable)
733688-031	Keyboard with backlight and pointing stick for use in the United Kingdom and Singapore (includes keyboard cable, backlight cable, and pointing stick cable)
733688-041	Keyboard with backlight and pointing stick for use in Germany (includes keyboard cable, backlight cable, and pointing stick cable)
733688-051	Keyboard with backlight and pointing stick for use in France (includes keyboard cable, backlight cable, and pointing stick cable)

<b>Spare part number</b>	<b>Description</b>
733688-061	Keyboard with backlight and pointing stick for use in Italy (includes keyboard cable, backlight cable, and pointing stick cable)
733688-071	Keyboard with backlight and pointing stick for use in Spain (includes keyboard cable, backlight cable, and pointing stick cable)
733688-081	Keyboard with backlight and pointing stick for use in Denmark (includes keyboard cable, backlight cable, and pointing stick cable)
733688-091	Keyboard with backlight and pointing stick for use in Norway (includes keyboard cable, backlight cable, and pointing stick cable)
733688-131	Keyboard with backlight and pointing stick for use in Portugal (includes keyboard cable, backlight cable, and pointing stick cable)
733688-141	Keyboard with backlight and pointing stick for use in Turkey (includes keyboard cable, backlight cable, and pointing stick cable)
733688-151	Keyboard with backlight and pointing stick for use in Greece (includes keyboard cable, backlight cable, and pointing stick cable)
733688-161	Keyboard with backlight and pointing stick for use in Latin America (includes keyboard cable, backlight cable, and pointing stick cable)
733688-171	Keyboard with backlight and pointing stick for use in Saudi Arabia (includes keyboard cable, backlight cable, and pointing stick cable)
733688-201	Keyboard with backlight and pointing stick for use in Brazil (includes keyboard cable, backlight cable, and pointing stick cable)
733688-211	Keyboard with backlight and pointing stick for use in Hungary (includes keyboard cable, backlight cable, and pointing stick cable)
733688-251	Keyboard with backlight and pointing stick for use in Russia (includes keyboard cable, backlight cable, and pointing stick cable)
733688-261	Keyboard with backlight and pointing stick for use in Bulgaria (includes keyboard cable, backlight cable, and pointing stick cable)
733688-271	Keyboard with backlight and pointing stick for use in Romania (includes keyboard cable, backlight cable, and pointing stick cable)
733688-281	Keyboard with backlight and pointing stick for use in Thailand (includes keyboard cable, backlight cable, and pointing stick cable)
733688-291	Keyboard with backlight and pointing stick for use in Japan (includes keyboard cable, backlight cable, and pointing stick cable)
733688-A41	Keyboard with backlight and pointing stick for use in Belgium (includes keyboard cable, backlight cable, and pointing stick cable)
733688-AB1	Keyboard with backlight and pointing stick for use in Taiwan (includes keyboard cable, backlight cable, and pointing stick cable)
733688-AD1	Keyboard with backlight and pointing stick for use in South Korea (includes keyboard cable, backlight cable, and pointing stick cable)
733688-B31	Keyboard with backlight and pointing stick for use in the Netherlands (includes keyboard cable, backlight cable, and pointing stick cable)

<b>Spare part number</b>	<b>Description</b>
733688-B71	Keyboard with backlight and pointing stick for use in Sweden and Finland (includes keyboard cable, backlight cable, and pointing stick cable)
733688-BA1	Keyboard with backlight and pointing stick for use in Slovenia (includes keyboard cable, backlight cable, and pointing stick cable)
733688-BB1	Keyboard with backlight and pointing stick for use in Israel (includes keyboard cable, backlight cable, and pointing stick cable)
733688-BG1	Keyboard with backlight and pointing stick for use in Switzerland (includes keyboard cable, backlight cable, and pointing stick cable)
733688-D61	Keyboard with backlight and pointing stick for use in India (includes keyboard cable, backlight cable, and pointing stick cable)
733688-DB1	Keyboard with backlight and pointing stick for use in Canada (includes keyboard cable, backlight cable, and pointing stick cable)
733688-DD1	Keyboard with backlight and pointing stick for use in Iceland (includes keyboard cable, backlight cable, and pointing stick cable)
733688-FL1	Keyboard with backlight and pointing stick for use in the Czech Republic and Slovakia (includes keyboard cable, backlight cable, and pointing stick cable)
733688-FP1	Keyboard with backlight and pointing stick for use in Northwest Africa (includes keyboard cable, backlight cable, and pointing stick cable)
734276-001	NVIDIA Quadro K1100M NVIDIA N15P-Q1 graphics board
734277-001	NVIDIA Quadro K2100M NVIDIA N15P-Q3 graphics board
734278-001	Service cover
734279-001	base enclosure
734280-001	Hard Drive Hardware Kit
734281-001	Top cover (includes TouchPad, TouchPad cable, and TouchPad bracket)
734282-001	Screw Kit
734283-001	Cable Kit (includes power connector cable and RJ-45 (network) cable and replacement thermal material)
734284-001	Function button board (includes cable and double-sided adhesive)
734285-001	Power button board (includes cable)
734286-001	Fingerprint reader board (includes cable and double-sided adhesive)
734287-001	ExpressCard assembly (includes activity LEDs and Thunderbolt port, Dual Mode DisplayPort, and USB port)
734288-001	Audio/USB board (includes SD Card reader)
734289-001	Fan/heat sink assembly for use only with an NVIDIA Quadro K1100M NVIDIA N15P-Q1 graphics board (includes replacement thermal material)
734290-001	Fan/heat sink assembly for use only with an NVIDIA Quadro K610M NVIDIA N15M-Q2 graphics board (includes replacement thermal material)



<b>Spare part number</b>	<b>Description</b>
734291-001	Fan/heat sink assembly for use only with an NVIDIA Quadro K2100M NVIDIA N15P-Q3 graphics board (includes replacement thermal material)
734292-001	Speakers
734293-001	USB board (includes cable and double-sided adhesive)
734294-001	Display hinge cover (includes HP logo)
734295-001	Webcamera/microphone module (includes double-sided adhesive)
734296-001	Display Panel Support Kit (includes display enclosure, display panel cable, and wireless antenna cables and transceivers)
734297-001	Plastics Kit
734298-001	Hard drive upgrade bay
734299-001	Bracket Kit
734300-001	RTC battery (includes cable and double-sided adhesive)
734301-001	Display bezel for use only on computer models equipped with a webcamera
734302-001	Display bezel for use only on computer models not equipped with a webcamera
734303-001	System board for use only on computer models equipped with an Intel Dual Core processor and the Linux operating system (includes battery connector bracket and replacement thermal material)
734303-501	System board for use only on computer models equipped with an Intel Dual Core processor and the Windows 8 Standard operating system (includes battery connector bracket and replacement thermal material)
734303-601	System board for use only on computer models equipped with an Intel Dual Core processor and the Windows 8 Professional operating system (includes battery connector bracket and replacement thermal material)
734304-001	System board for use only on computer models equipped with an Intel Quad Core processor and the Linux operating system (includes battery connector bracket and replacement thermal material)
734304-501	System board for use only on computer models equipped with an Intel Quad Core processor and the Windows 8 Standard operating system (includes battery connector bracket and replacement thermal material)
734304-601	System board for use only on computer models equipped with an Intel Quad Core processor and the Windows 8 Professional operating system (includes battery connector bracket and replacement thermal material)
735370-001	Microphone module (includes double-sided adhesive)
735594-001	32-GB mSATA flash cache solid-state drive
735595-001	128-GB mSATA-3 solid-state drive
735596-001	128-GB SATA-3 solid-state drive
735597-001	180-GB SATA-3 solid-state drive
735598-001	256-GB SATA-3 self-encrypting solid-state drive
735599-001	Blu-ray ROM DVD±RW SuperMulti Double-Layer Drive

<b>Spare part number</b>	<b>Description</b>
735600-001	Blu-ray R/RE DVD±RW SuperMulti Double-Layer Drive
735601-001	DVD-ROM Drive
735602-001	DVD±RW SuperMulti Double-Layer Drive
735604-001	15.6-in, FHD, SVA, LED display panel
735607-001	15.6-in, FHD, UWVA, LED display panel
735964-001	15.6-in, FHD, UWVA, DreamVision display assembly not equipped with a webcam
735965-001	15.6-in, FHD, UWVA, DreamVision display assembly equipped with a webcam
737330-002	Intel Quad Core i7-4600M 2.90-GHz (SC turbo up to 3.60-GHz) processor (1600-MHz FSB, 4.0-MB L3 cache, 37 W; includes replacement thermal material)
738201-002	Intel Dual Core i5-4330M 2.80-GHz (SC turbo up to 3.50-GHz) processor (1600-MHz FSB, 3.0-MB L3 cache, 37 W; includes replacement thermal material)
738309-002	Intel Dual Core i5-4300M 2.60-GHz (SC turbo up to 3.30-GHz) processor (1600-MHz FSB, 3.0-MB L3 cache, 37 W; includes replacement thermal material)
738311-001	Hinge Kit (includes left and right hinges and display panel cable bracket)
738714-001	512-GB SATA-3 solid-state drive
742159-001	Smart card reader (includes cable)
745325-001	NVIDIA Quadro K610M NVIDIA N15M-Q2 graphics board
745663-001	Keyboard with pointing stick for use in the United States (includes keyboard cable and pointing stick cable)
745663-031	Keyboard with pointing stick for use in the United Kingdom and Singapore (includes keyboard cable and pointing stick cable)
745663-041	Keyboard with pointing stick for use in Germany (includes keyboard cable and pointing stick cable)
745663-051	Keyboard with pointing stick for use in France (includes keyboard cable and pointing stick cable)
745663-061	Keyboard with pointing stick for use in Italy (includes keyboard cable and pointing stick cable)
745663-071	Keyboard with pointing stick for use in Spain (includes keyboard cable and pointing stick cable)
745663-081	Keyboard with pointing stick for use in Denmark (includes keyboard cable and pointing stick cable)
745663-091	Keyboard with pointing stick for use in Norway (includes keyboard cable and pointing stick cable)
745663-131	Keyboard with pointing stick for use in Portugal (includes keyboard cable and pointing stick cable)
745663-141	Keyboard with pointing stick for use in Turkey (includes keyboard cable and pointing stick cable)
745663-151	Keyboard with pointing stick for use in Greece (includes keyboard cable and pointing stick cable)
745663-161	Keyboard with pointing stick for use in Latin America (includes keyboard cable and pointing stick cable)
745663-171	Keyboard with pointing stick for use in Saudi Arabia (includes keyboard cable and pointing stick cable)
745663-201	Keyboard with pointing stick for use in Brazil (includes keyboard cable and pointing stick cable)

<b>Spare part number</b>	<b>Description</b>
745663-211	Keyboard with pointing stick for use in Hungary (includes keyboard cable and pointing stick cable)
745663-251	Keyboard with pointing stick for use in Russia (includes keyboard cable and pointing stick cable)
745663-261	Keyboard with pointing stick for use in Bulgaria (includes keyboard cable and pointing stick cable)
745663-271	Keyboard with pointing stick for use in Romania (includes keyboard cable and pointing stick cable)
745663-281	Keyboard with pointing stick for use in Thailand (includes keyboard cable and pointing stick cable)
745663-291	Keyboard with pointing stick for use in Japan (includes keyboard cable and pointing stick cable)
745663-A41	Keyboard with pointing stick for use in Belgium (includes keyboard cable and pointing stick cable)
745663-AB1	Keyboard with pointing stick for use in Taiwan (includes keyboard cable and pointing stick cable)
745663-AD1	Keyboard with pointing stick for use in South Korea (includes keyboard cable and pointing stick cable)
745663-B31	Keyboard with pointing stick for use in the Netherlands (includes keyboard cable and pointing stick cable)
745663-B71	Keyboard with pointing stick for use in Sweden and Finland (includes keyboard cable and pointing stick cable)
745663-BA1	Keyboard with pointing stick for use in Slovenia (includes keyboard cable and pointing stick cable)
745663-BB1	Keyboard with pointing stick for use in Israel (includes keyboard cable and pointing stick cable)
745663-BG1	Keyboard with pointing stick for use in Switzerland (includes keyboard cable and pointing stick cable)
745663-DB1	Keyboard with pointing stick for use in Canada (includes keyboard cable and pointing stick cable)
745663-DD1	Keyboard with pointing stick for use in Iceland (includes keyboard cable and pointing stick cable)
745663-FL1	Keyboard with pointing stick for use in the Czech Republic and Slovakia (includes keyboard cable and pointing stick cable)
745663-FP1	Keyboard with pointing stick for use in Northwest Africa (includes keyboard cable and pointing stick cable)

---

# 4 Removal and replacement procedures preliminary requirements

## Tools required

You will need the following tools to complete the removal and replacement procedures:

- Flat-bladed screw driver
- Magnetic screw driver
- Phillips P0 and P1 screw drivers

## Service considerations

The following sections include some of the considerations that you must keep in mind during disassembly and assembly procedures.



---

**NOTE:** As you remove each subassembly from the computer, place the subassembly (and all accompanying screws) away from the work area to prevent damage.

---

## Plastic parts



---

**CAUTION:** Using excessive force during disassembly and reassembly can damage plastic parts. Use care when handling the plastic parts. Apply pressure only at the points designated in the maintenance instructions.

---

## Cables and connectors

---

**⚠ CAUTION:** When servicing the computer, be sure that cables are placed in their proper locations during the reassembly process. Improper cable placement can damage the computer.

---

Cables must be handled with extreme care to avoid damage. Apply only the tension required to unseat or seat the cables during removal and insertion. Handle cables by the connector whenever possible. In all cases, avoid bending, twisting, or tearing cables. Be sure that cables are routed in such a way that they cannot be caught or snagged by parts being removed or replaced. Handle flex cables with extreme care; these cables tear easily.

## Drive handling

---

**⚠ CAUTION:** Drives are fragile components that must be handled with care. To prevent damage to the computer, damage to a drive, or loss of information, observe these precautions:

Before removing or inserting a hard drive, shut down the computer. If you are unsure whether the computer is off or in Hibernation, turn the computer on, and then shut it down through the operating system.

Before handling a drive, be sure that you are discharged of static electricity. While handling a drive, avoid touching the connector.

Before removing a diskette drive or optical drive, be sure that a diskette or disc is not in the drive and be sure that the optical drive tray is closed.

Handle drives on surfaces covered with at least one inch of shock-proof foam.

Avoid dropping drives from any height onto any surface.

After removing a hard drive, an optical drive, or a diskette drive, place it in a static-proof bag.

Avoid exposing an internal hard drive to products that have magnetic fields, such as monitors or speakers.

Avoid exposing a drive to temperature extremes or liquids.

If a drive must be mailed, place the drive in a bubble pack mailer or other suitable form of protective packaging and label the package "FRAGILE."

---

# Grounding guidelines

## Electrostatic discharge damage

Electronic components are sensitive to electrostatic discharge (ESD). Circuitry design and structure determine the degree of sensitivity. Networks built into many integrated circuits provide some protection, but in many cases, ESD contains enough power to alter device parameters or melt silicon junctions.

A discharge of static electricity from a finger or other conductor can destroy static-sensitive devices or microcircuitry. Even if the spark is neither felt nor heard, damage may have occurred.

An electronic device exposed to ESD may not be affected at all and can work perfectly throughout a normal cycle. Or the device may function normally for a while, then degrade in the internal layers, reducing its life expectancy.

**⚠ CAUTION:** To prevent damage to the computer when you are removing or installing internal components, observe these precautions:

Keep components in their electrostatic-safe containers until you are ready to install them.

Before touching an electronic component, discharge static electricity by using the guidelines described in this section.

Avoid touching pins, leads, and circuitry. Handle electronic components as little as possible.

If you remove a component, place it in an electrostatic-safe container.

The following table shows how humidity affects the electrostatic voltage levels generated by different activities.

**⚠ CAUTION:** A product can be degraded by as little as 700 V.

Typical electrostatic voltage levels			
Event	Relative humidity		
	10%	40%	55%
Walking across carpet	35,000 V	15,000 V	7,500 V
Walking across vinyl floor	12,000 V	5,000 V	3,000 V
Motions of bench worker	6,000 V	800 V	400 V
Removing DIPS from plastic tube	2,000 V	700 V	400 V
Removing DIPS from vinyl tray	11,500 V	4,000 V	2,000 V
Removing DIPS from Styrofoam	14,500 V	5,000 V	3,500 V
Removing bubble pack from PCB	26,500 V	20,000 V	7,000 V
Packing PCBs in foam-lined box	21,000 V	11,000 V	5,000 V

## Packaging and transporting guidelines

Follow these grounding guidelines when packaging and transporting equipment:

- To avoid hand contact, transport products in static-safe tubes, bags, or boxes.
- Protect ESD-sensitive parts and assemblies with conductive or approved containers or packaging.
- Keep ESD-sensitive parts in their containers until the parts arrive at static-free workstations.
- Place items on a grounded surface before removing items from their containers.
- Always be properly grounded when touching a component or assembly.
- Store reusable ESD-sensitive parts from assemblies in protective packaging or nonconductive foam.
- Use transporters and conveyors made of antistatic belts and roller bushings. Be sure that mechanized equipment used for moving materials is wired to ground and that proper materials are selected to avoid static charging. When grounding is not possible, use an ionizer to dissipate electric charges.

## Workstation guidelines

Follow these grounding workstation guidelines:

- Cover the workstation with approved static-shielding material.
- Use a wrist strap connected to a properly grounded work surface and use properly grounded tools and equipment.
- Use conductive field service tools, such as cutters, screw drivers, and vacuums.
- When fixtures must directly contact dissipative surfaces, use fixtures made only of static-safe materials.
- Keep the work area free of nonconductive materials, such as ordinary plastic assembly aids and Styrofoam.
- Handle ESD-sensitive components, parts, and assemblies by the case or PCM laminate. Handle these items only at static-free workstations.
- Avoid contact with pins, leads, or circuitry.
- Turn off power and input signals before inserting or removing connectors or test equipment.

## Equipment guidelines

Grounding equipment must include either a wrist strap or a foot strap at a grounded workstation.

- When seated, wear a wrist strap connected to a grounded system. Wrist straps are flexible straps with a minimum of one megohm  $\pm 10\%$  resistance in the ground cords. To provide proper ground, wear a strap snugly against the skin at all times. On grounded mats with banana-plug connectors, use alligator clips to connect a wrist strap.
- When standing, use foot straps and a grounded floor mat. Foot straps (heel, toe, or boot straps) can be used at standing workstations and are compatible with most types of shoes or boots. On conductive floors or dissipative floor mats, use foot straps on both feet with a minimum of one megohm resistance between the operator and ground. To be effective, the conductive must be worn in contact with the skin.

The following grounding equipment is recommended to prevent electrostatic damage:

- Antistatic tape
- Antistatic smocks, aprons, and sleeve protectors
- Conductive bins and other assembly or soldering aids
- Nonconductive foam
- Conductive tabletop workstations with ground cords of one megohm resistance
- Static-dissipative tables or floor mats with hard ties to the ground
- Field service kits
- Static awareness labels
- Material-handling packages
- Nonconductive plastic bags, tubes, or boxes
- Metal tote boxes
- Electrostatic voltage levels and protective materials

The following table lists the shielding protection provided by antistatic bags and floor mats.

<b>Material</b>	<b>Use</b>	<b>Voltage protection level</b>
Antistatic plastics	Bags	1,500 V
Carbon-loaded plastic	Floor mats	7,500 V
Metallized laminate	Floor mats	5,000 V



---

# 5 Removal and replacement procedures for Customer Self-Repair parts

---

 **NOTE:** The Customer Self-Repair program is not available in all locations. Installing a part not supported by the Customer Self-Repair program may void your warranty. Check your warranty to determine if Customer Self-Repair is supported in your location.

---

## Component replacement procedures

---

 **NOTE:** Please read and follow the procedures described here to access and replace Customer Self-Repair parts successfully.

 **NOTE:** Details about your computer, including model, serial number, product key, and length of warranty, are on the service tag at the bottom of your computer. See Service tag on page 16 for details.

---

This chapter provides removal and replacement procedures for Customer Self-Repair parts.

There are as many as 16 screws that must be removed, replaced, and/or loosened when servicing Customer Self-Repair parts. Make special note of each screw size and location during removal and replacement.

## Battery

Description	Spare part number
9-cell, 100-WHr, 3.0-AHr, Li-ion battery	634087-001
9-cell, 73-WHr, 2.2-AHr, Li-ion battery	634089-001
8-cell, 83-WHr, 2.8-AHr, Li-ion battery	708456-001
8-cell, 75-WHr, 2.8-AHr, Li-ion battery	708455-001

Before removing the battery, follow these steps:

1. Turn off the computer. If you are unsure whether the computer is off or in Hibernation, turn the computer on, and then shut it down through the operating system.
2. Disconnect the power from the computer by unplugging the power cord from the computer.
3. Disconnect all external devices from the computer.

Remove the battery:

 **WARNING!** To reduce potential safety issues, use only the user-replaceable battery provided with the computer, a replacement battery provided by HP, or a compatible battery purchased from HP.

 **CAUTION:** Removing a user-replaceable battery that is the sole power source for the computer can cause loss of information. To prevent loss of information, save your work or shut down the computer through Windows before removing the battery.

1. Turn the computer upside down on a flat surface.
2. Slide the battery release latch **(1)** to release the battery.

 **NOTE:** The battery release latch automatically returns to its original position.

3. Pivot the battery **(2)** upward.

4. Remove the battery **(3)** from the computer.

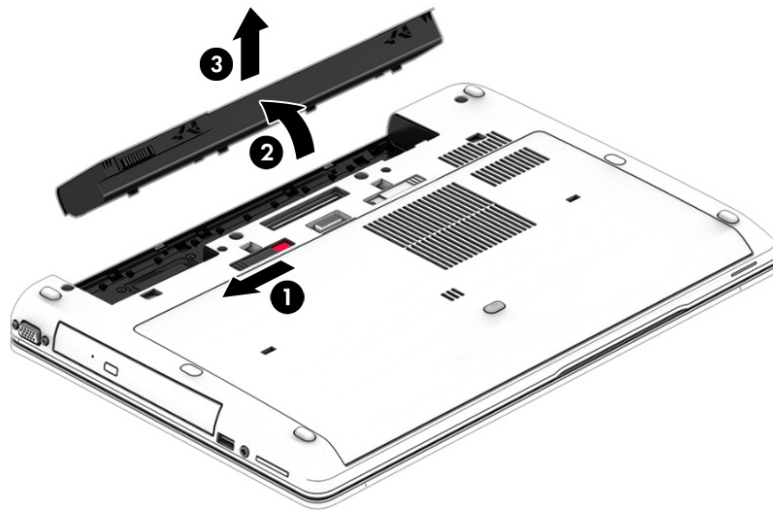

Reverse this procedure to install the battery.

## Service cover

Description	Spare part number
Service cover	734278-001

Before removing the service cover, follow these steps:

1. Turn off the computer. If you are unsure whether the computer is off or in Hibernation, turn the computer on, and then shut it down through the operating system.
2. Disconnect the power from the computer by unplugging the power cord from the computer.
3. Disconnect all external devices from the computer.
4. Remove the battery (see [Battery on page 50](#)).

Remove the service cover:

1. Slide the service cover release latch to the left **(1)**, and then remove the optional Phillips PM2.0x4.5 screw (if the screw is being used) **(2)**.



**NOTE:** If you want to use the optional screw, it is stored inside the service cover.

2. Slide the release latch again **(3)** to release the service cover.

- Slide the service cover toward the front of the computer **(4)**, and then lift to remove the service cover **(5)**.

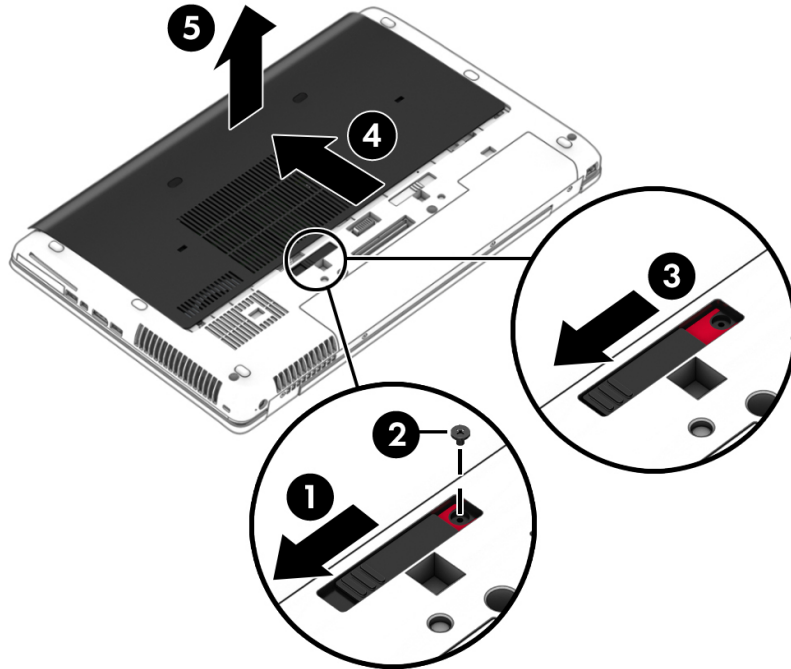

Reverse this procedure to install the service cover.

## Hard drive

**NOTE:** The hard drive spare part kit does not include the hard drive bracket or screws. These components are included in the Hard Drive Hardware Kit, spare part number 734280-001.

Description	Spare part number
1-TB, 5400-rpm, 9.5-mm	676521-001
750-GB, 7200-rpm, 7.0-mm	633252-001
500-GB, 7200-rpm, 7.0-mm	703267-001
500-GB, 5400-rpm, 7.0-mm, FIPS	730946-001
500-GB, 7200-rpm, 7.0-mm, self-encrypting	703268-001
320-GB, 7200-rpm, 7.0-mm	634862-001

Before removing the hard drive, follow these steps:

- Turn off the computer. If you are unsure whether the computer is off or in Hibernation, turn the computer on, and then shut it down through the operating system.
- Disconnect the power from the computer by unplugging the power cord from the computer.
- Disconnect all external devices from the computer.

4. Remove the battery (see [Battery on page 50](#)).
5. Remove the service cover (see [Service cover on page 51](#)).

Remove the hard drive:

1. Loosen the 3 hard drive captive screws **(1)**.
2. Pull the hard drive tab **(2)** to the left to disconnect the hard drive.
3. Lift the hard drive **(3)**, and then pull the hard drive out of the hard drive bay.

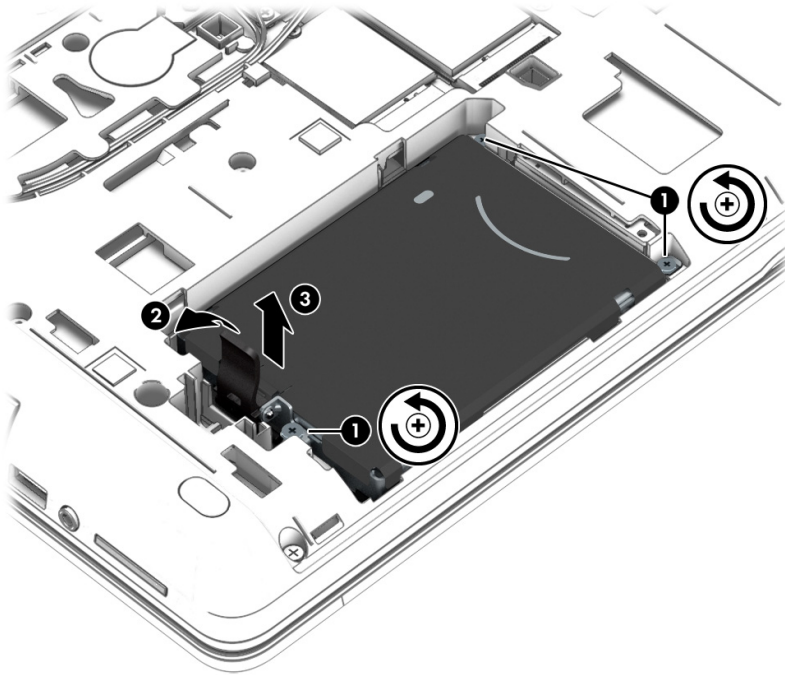

4. If it is necessary to disassemble the hard drive, perform the following steps:
  - a. Position the hard drive with the hard drive tab toward you.
  - b. Remove the four Phillips PM3.0×3.5 screws **(1)** that secure the hard drive bracket to the hard drive.
  - c. Remove the hard drive bracket **(2)** from the hard drive.

The hard drive bracket and screws are available in the Hard Drive Hardware Kit, spare part number 734280-001.

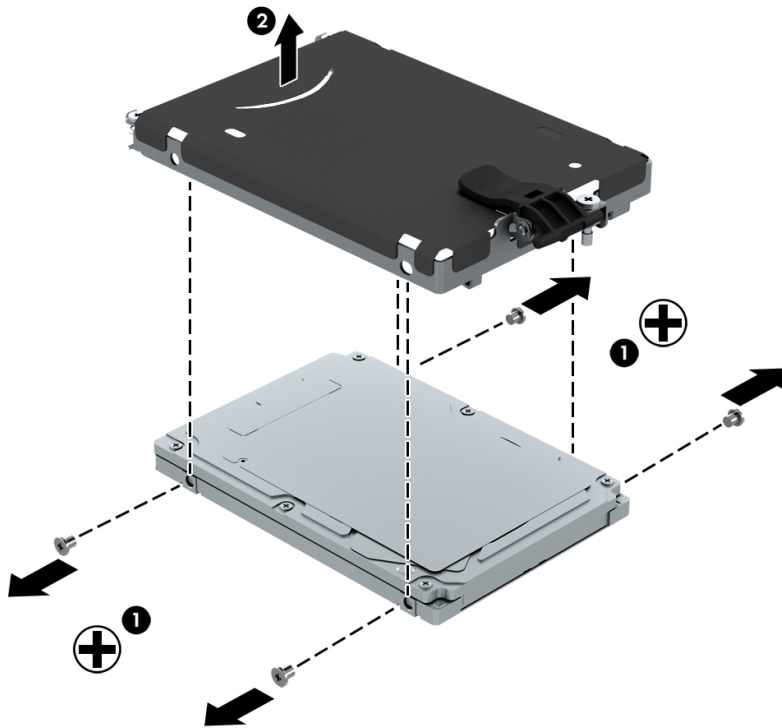

Reverse this procedure to install the hard drive.

## Optical drive



**NOTE:** The optical drive spare part kit includes a bezel and bracket.

Description	Spare part number
Blu-ray R/RE DVD±RW SuperMulti Double-Layer Drive	735600-001
Blu-ray ROM DVD±RW SuperMulti Double-Layer Drive	735599-001
DVD±RW SuperMulti Double-Layer Drive	735602-001
DVD-ROM Drive	735601-001
Hard drive upgrade bay	734298-001

Before removing the optical drive, follow these steps:

1. Turn off the computer. If you are unsure whether the computer is off or in Hibernation, turn the computer on, and then shut it down through the operating system.
2. Disconnect the power from the computer by unplugging the power cord from the computer.
3. Disconnect all external devices from the computer.

4. Remove the battery (see [Battery on page 50](#)).
5. Remove the service cover (see [Service cover on page 51](#)).

Remove the optical drive:

1. Position the computer with the left side toward you.
2. Loosen the captive screw **(1)** that secures the optical drive to the computer.
3. Insert a thin tool into the optical drive tab access **(2)** and press the tab to the left to release the optical drive from the computer.
4. Remove the optical drive **(3)**.

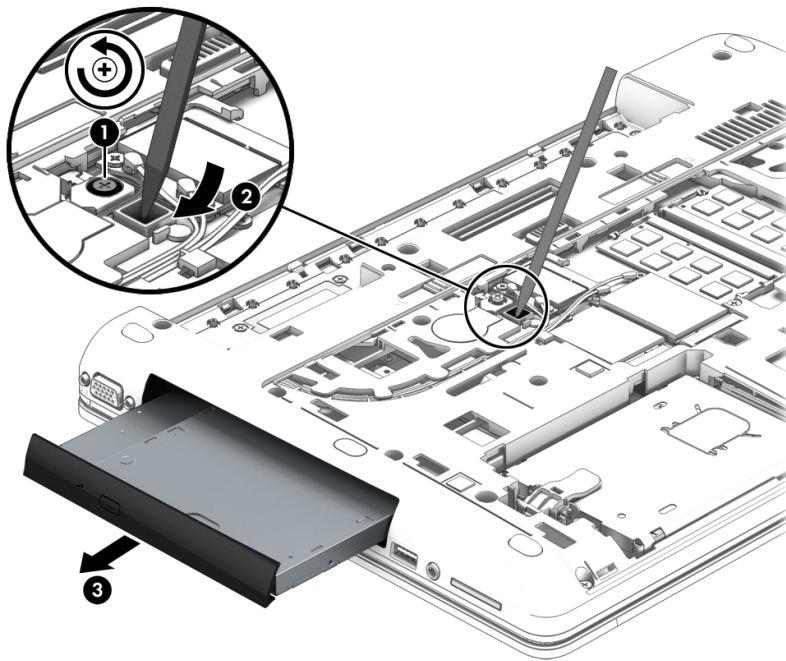

Reverse this procedure to install the optical drive.

## WWAN module

Description	Spare part number
HP hs3110 HSPA+ Mobile Broadband Module	723895-001
HP It4111 LTE/EV-DO/HSPA+ Mobile Broadband Module	704030-001
HP It4112 LTE/HSPA+ Mobile Broadband Module	704031-001

 **CAUTION:** To prevent an unresponsive system, replace the wireless module only with a wireless module authorized for use in the computer by the governmental agency that regulates wireless devices in your country or region. If you replace the module and then receive a warning message, remove the module to restore device functionality, and then contact technical support.

Before removing the WWAN module, follow these steps:

1. Turn off the computer. If you are unsure whether the computer is off or in Hibernation, turn the computer on, and then shut it down through the operating system.
2. Disconnect the power from the computer by unplugging the power cord from the computer.
3. Disconnect all external devices from the computer.
4. Remove the battery (see [Battery on page 50](#)).
5. Remove the service cover (see [Optical drive on page 54](#)).

Remove the WWAN module:

1. Disconnect the WWAN antenna cables **(1)** from the terminals on the WWAN module.

 **NOTE:** The WWAN antenna cable labeled “5” connects to the WWAN module “Main” terminal labeled “5”. The WWAN antenna cable labeled “6” connects to the WWAN module “Aux/GPS” terminal labeled “6”.

2. Remove the Phillips PM2.0×3.25 screw **(2)** that secures the WWAN module to the system board. (The WWAN module tilts up.)



3. Remove the WWAN module **(3)** by pulling the module away from the slot at an angle.

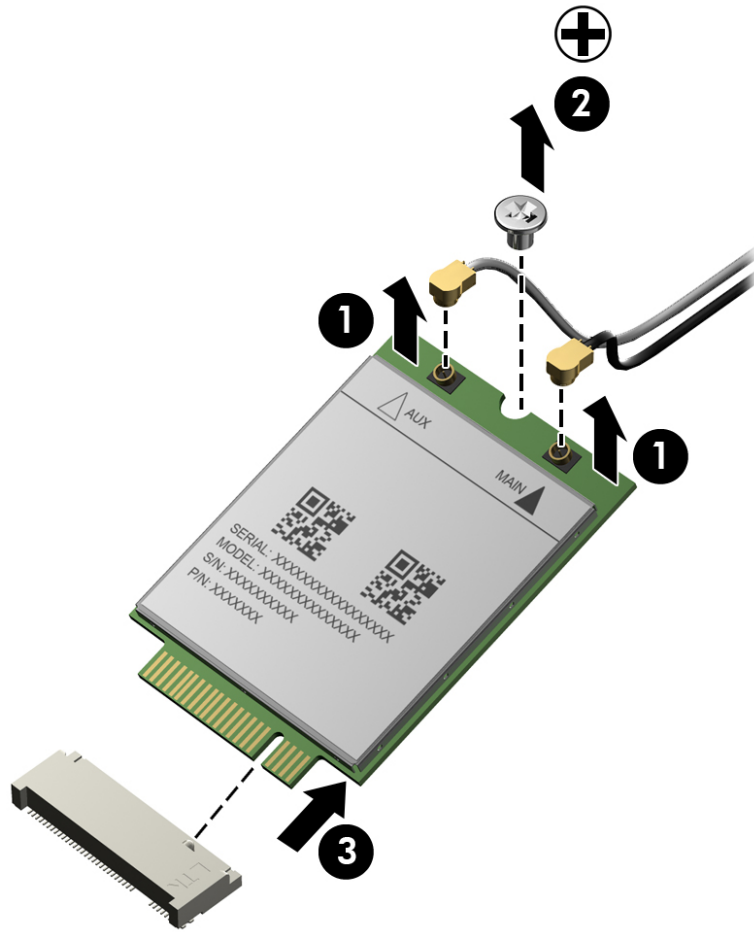

**NOTE:** If the WWAN antenna cables are not connected to the terminals on the WWAN module, protective sleeves should be installed on the antenna connectors, as shown in the following illustration.

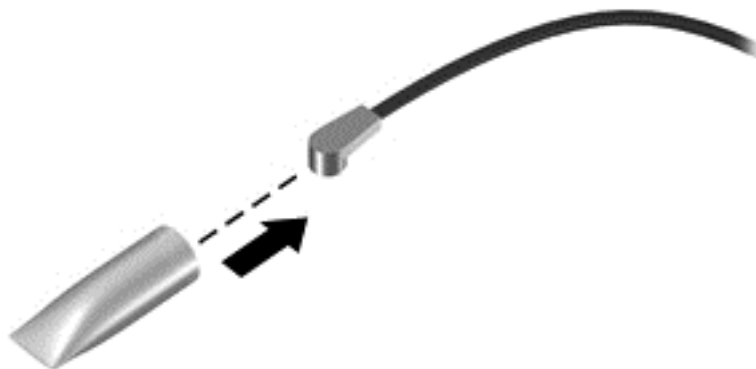

Reverse this procedure to install the WWAN module.

## Solid-state drive

Description	Spare part number
512-GB SATA-3 SSD	738714-001
256-GB SATA-3 self-encrypting SSD	735598-001
180-GB SATA-3 SSD	735597-001
128-GB SATA-3 SSD	735596-001
128-GB mSATA-3 SSD	735595-001
32-GB mSATA flash cache SSD	735594-001

Before removing the solid-state drive, follow these steps:

1. Turn off the computer. If you are unsure whether the computer is off or in Hibernation, turn the computer on, and then shut it down through the operating system.
2. Disconnect the power from the computer by unplugging the power cord from the computer.
3. Disconnect all external devices from the computer.
4. Remove the battery (see [Battery on page 50](#)).
5. Remove the service cover (see [Service cover on page 51](#)).

Remove the solid-state drive:

1. Remove the two Phillips PM2.0×3.5 screws **(1)** that secure the solid-state drive to the system board. (The solid-state drive tilts up.)
2. Remove the solid-state drive **(2)** by pulling the drive away from the slot at an angle.

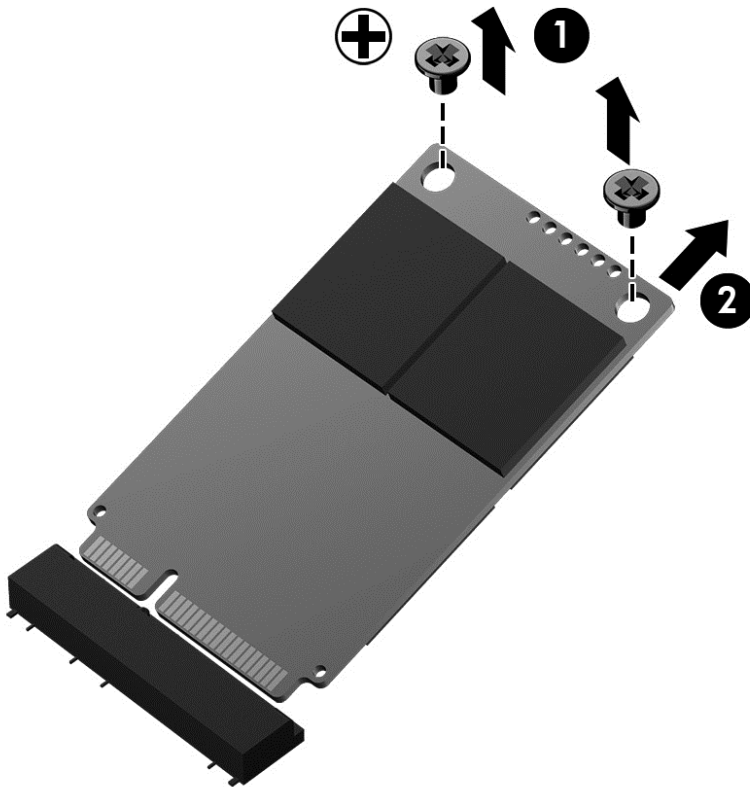

Reverse this procedure to install the solid-state drive.

## WLAN module

Description	Spare part number
Intel Centrino Advanced-N 6205 Combo Adapter	695915-001
Intel Centrino Advanced-N 6235 Combo Adapter	670292-001
Intel Dual Band Wireless-AC 7260 802.11 ac 2x2 WiFi + BT 4.0 Combo Adapter	710661-001

**CAUTION:** To prevent an unresponsive system, replace the wireless module only with a wireless module authorized for use in the computer by the governmental agency that regulates wireless devices in your country or region. If you replace the module and then receive a warning message, remove the module to restore device functionality, and then contact technical support.

Before removing the WLAN module, follow these steps:

1. Turn off the computer. If you are unsure whether the computer is off or in Hibernation, turn the computer on, and then shut it down through the operating system.
2. Disconnect the power from the computer by unplugging the power cord from the computer.
3. Disconnect all external devices from the computer.

4. Remove the battery (see [Battery on page 50](#)).
5. Remove the service cover (see [Service cover on page 51](#)).

Remove the WLAN module:

1. Disconnect the WLAN antenna cables (**1**) from the terminals on the WLAN module.

 **NOTE:** The WLAN antenna cable labeled “1” connects to the WLAN module “Main” terminal labeled “1”. The WLAN antenna cable labeled “2” connects to the WLAN module “Aux” terminal labeled “2”.

2. Remove the two Phillips PM2.0x3.0 screws (**2**) that secure the WLAN module to the system board. (The WLAN module tilts up.)
3. Remove the WLAN module (**3**) by pulling the module away from the slot at an angle.

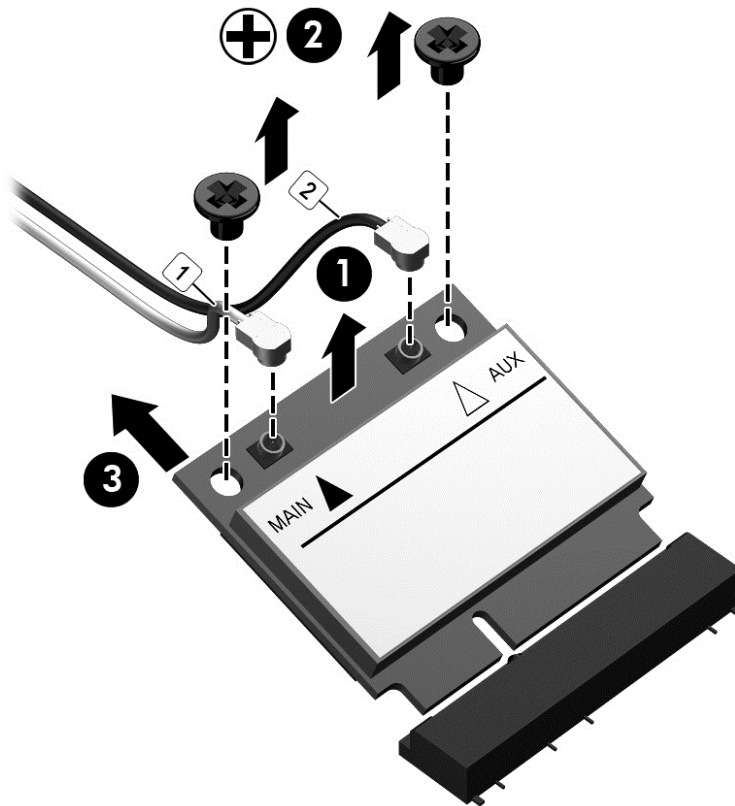

 **NOTE:** If the WLAN antenna cables are not connected to the terminals on the WLAN module, protective sleeves should be installed on the antenna connectors, as shown in the following illustration.

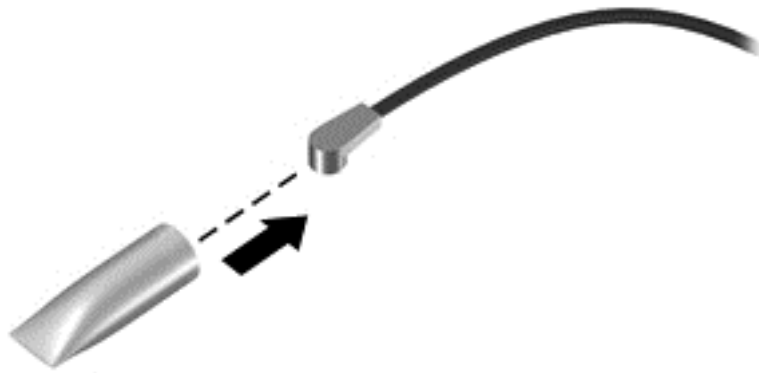

Reverse this procedure to install the WLAN module.

## Primary memory module

Description	Spare part number
8-GB (PC3L, 12800, 1600-MHz)	693374-001
4-GB (PC3L, 12800, 1600-MHz)	691740-001

### Update BIOS before adding memory modules

Before adding new memory, make sure you update the computer to the latest BIOS.

**CAUTION:** Failure to update the computer to the latest BIOS prior to installing new memory may result in various system problems.

To update BIOS:

1. Navigate to [www.hp.com](http://www.hp.com).
2. Click **Support & Drivers > click Drivers & Software**.
3. In the **Enter a product name/number box**, type the computer model information, and then click **Search**.
4. Click the link for the computer model.
5. Select the operating system, and then click **Next**.
6. Under **Step 2: Select a Download**, click the **BIOS** link.
7. Click the link for the most recent BIOS.
8. Click the **Download** button, and then follow the on-screen instructions.

Before removing a memory module, follow these steps:

1. Turn off the computer. If you are unsure whether the computer is off or in Hibernation, turn the computer on, and then shut it down through the operating system.
2. Disconnect the power from the computer by unplugging the power cord from the computer.

3. Disconnect all external devices from the computer.
4. Remove the battery (see [Battery on page 50](#)).
5. Remove the service cover (see [Optical drive on page 54](#)).

Remove the memory module:

1. Spread the retaining tabs **(1)** on each side of the memory module slot to release the memory module. (The memory module tilts up.)
2. Remove the memory module **(2)** by pulling the module away from the slot at an angle.

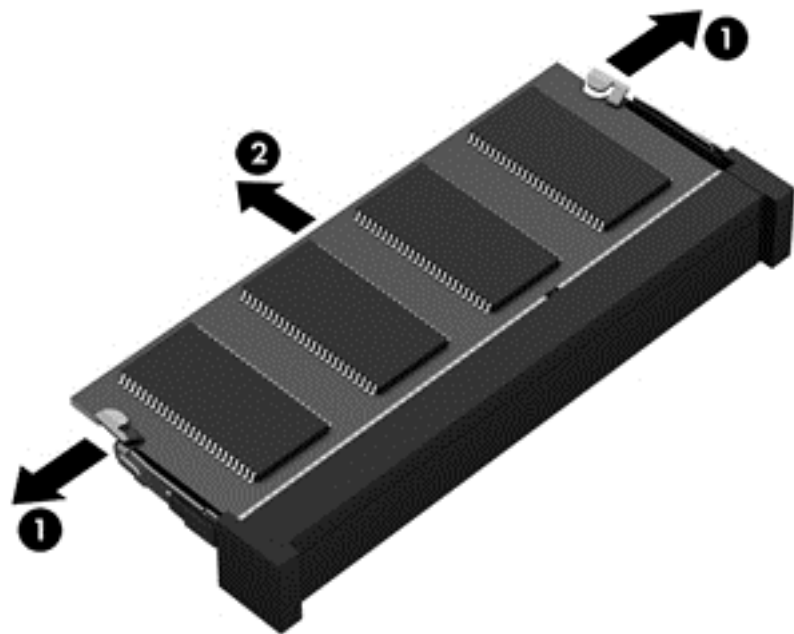

Reverse this procedure to install a memory module.

## Keyboard

For use in country or region	Spare part number	For use in country or region	Spare part number
Keyboard with backlight and pointing stick (includes keyboard cable, backlight cable, and pointing stick cable):		For use in the Netherlands	733688-B31
For use in Belgium	733688-A41	For use in Northwest Africa	733688-FP1
For use in Brazil	733688-201	For use in Norway	733688-091
For use in Bulgaria	733688-261	For use in Portugal	733688-131
For use in Canada	733688-DB1	For use in Romania	733688-271
For use in the Czech Republic and Slovakia	733688-FL1	For use in Russia	733688-251
For use in Denmark	733688-081	For use in Saudi Arabia	733688-171

<b>For use in country or region</b>	<b>Spare part number</b>	<b>For use in country or region</b>	<b>Spare part number</b>
For use in France	733688-051	For use in Slovenia	733688-BA1
For use in Germany	733688-041	For use in South Korea	733688-AD1
For use in Greece	733688-151	For use in Spain	733688-071
For use in Hungary	733688-211	For use in Sweden and Finland	733688-B71
For use in Iceland	733688-DD1	For use in Switzerland	733688-BG1
For use in India	733688-D61	For use in Taiwan	733688-AB1
For use in Israel	733688-BB1	For use in Thailand	733688-281
For use in Italy	733688-061	For use in Turkey	733688-141
For use in Japan	733688-291	For use in the United Kingdom and Singapore	733688-031
For use in Latin America	733688-161	For use in the United States	733688-001
Keyboard with pointing stick (includes keyboard cable and pointing stick cable):			
For use in Belgium	745663-A41	For use in Northwest Africa	745663-FP1
For use in Brazil	745663-201	For use in Norway	745663-091
For use in Bulgaria	745663-261	For use in Portugal	745663-131
For use in Canada	745663-DB1	For use in Romania	745663-271
For use in the Czech Republic and Slovakia	745663-FL1	For use in Russia	745663-251
For use in Denmark	745663-081	For use in Saudi Arabia	745663-171
For use in France	745663-051	For use in Slovenia	745663-BA1
For use in Germany	745663-041	For use in South Korea	745663-AD1
For use in Greece	745663-151	For use in Spain	745663-071
For use in Hungary	745663-211	For use in Sweden and Finland	745663-B71
For use in Iceland	745663-DD1	For use in Switzerland	745663-BG1
For use in Israel	745663-BB1	For use in Taiwan	745663-AB1
For use in Italy	745663-061	For use in Thailand	745663-281
For use in Japan	745663-291	For use in Turkey	745663-141
For use in Latin America	745663-161	For use in the United Kingdom and Singapore	745663-031
For use in the Netherlands	745663-B31	For use in the United States	745663-001

Before removing the keyboard, follow these steps:

1. Turn off the computer. If you are unsure whether the computer is off or in Hibernation, turn the computer on, and then shut it down through the operating system.
2. Disconnect the power from the computer by unplugging the power cord from the computer.
3. Disconnect all external devices from the computer.
4. Remove the battery (see [Battery on page 50](#)).
5. Remove the service cover (see [Service cover on page 51](#)).
6. Remove the optical drive (see [Optical drive on page 54](#)).

Remove the keyboard:

1. Loosen the two captive screws that secure the keyboard to the computer.

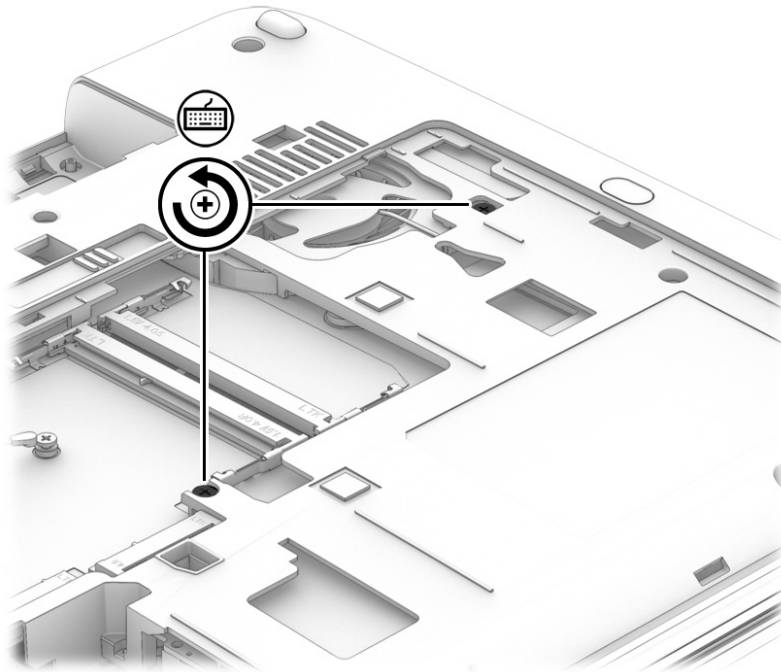

2. Partially open the computer.
3. Rest and secure the computer on its left side.



4. Insert a thin tool into the keyboard release hole in the optical drive bay, and then press on the back of the keyboard until the keyboard disengages from the computer.

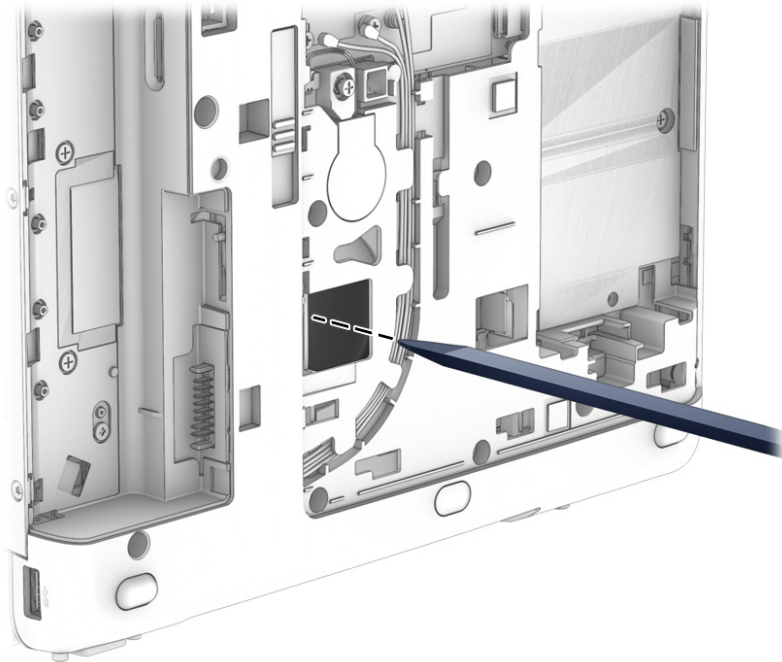

5. Turn the computer right-side up, with the front toward you.
6. Open the computer as far as it will open.
7. Lift the rear edge of the keyboard until it rests at an angle.
8. Swing the rear edge of the keyboard **(1)** up and forward until it rests upside down on the palm rest.
9. Release the zero insertion force (ZIF) connector **(2)** to which the keyboard cable is attached, and then disconnect the keyboard cable from the system board.
10. Release the ZIF connector **(3)** to which the pointing stick cable is attached, and then disconnect the pointing stick cable from the system board.



---

**NOTE:** Step 11 applies only to computer models equipped with a keyboard with backlight.

---

11. Release the ZIF connector **(4)** to which the backlight cable is attached, and then disconnect the backlight cable from the system board.

12. Remove the keyboard (5).

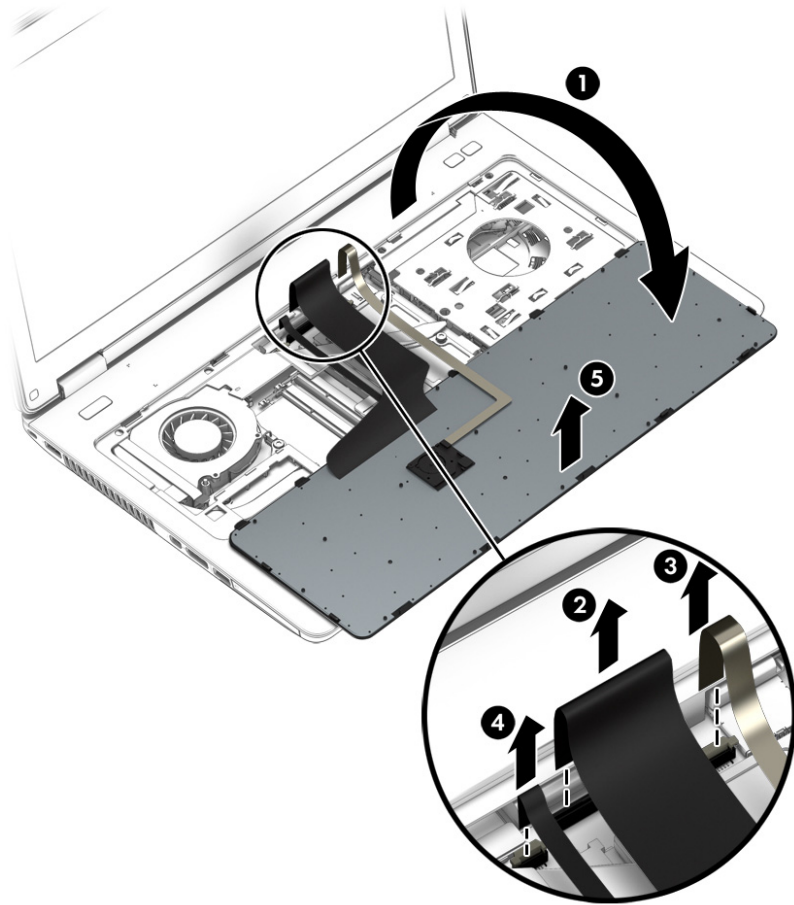

Reverse this procedure to install the keyboard.

## Expansion memory module

Description	Spare part number
8-GB (PC3L, 12800, 1600-MHz)	693374-001
4-GB (PC3L, 12800, 1600-MHz)	691740-001

### Update BIOS before adding memory modules

Before adding new memory, make sure you update the computer to the latest BIOS.

**CAUTION:** Failure to update the computer to the latest BIOS prior to installing new memory may result in various system problems.

To update BIOS:

1. Navigate to [www.hp.com](http://www.hp.com).
2. Click **Support & Drivers > click Drivers & Software**.
3. In the **Enter a product name/number box**, type the computer model information, and then click **Search**.
4. Click the link for the computer model.
5. Select the operating system, and then click **Next**.
6. Under **Step 2: Select a Download**, click the **BIOS** link.
7. Click the link for the most recent BIOS.
8. Click the **Download** button, and then follow the on-screen instructions.

Before removing a memory module, follow these steps:

1. Turn off the computer. If you are unsure whether the computer is off or in Hibernation, turn the computer on, and then shut it down through the operating system.
2. Disconnect the power from the computer by unplugging the power cord from the computer.
3. Disconnect all external devices from the computer.
4. Remove the battery (see [Battery on page 50](#)).
5. Remove the service cover (see [Optical drive on page 54](#)).

Remove the memory module:

1. Spread the retaining tabs **(1)** on each side of the memory module slot to release the memory module. (The memory module tilts up.)

2. Remove the memory module **(2)** by pulling the module away from the slot at an angle.

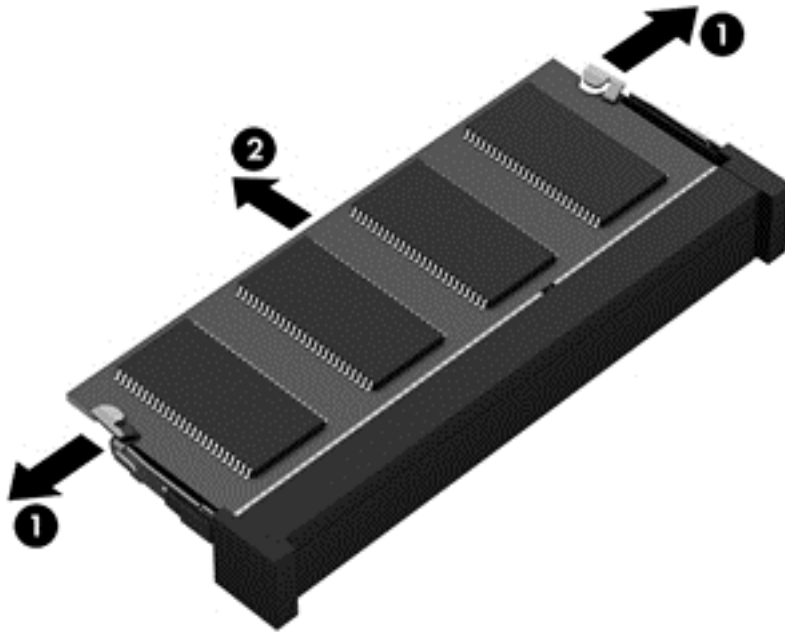

Reverse this procedure to install a memory module.

---

# 6 Removal and replacement procedures for Authorized Service Provider parts

**⚠ CAUTION:** Components described in this chapter should only be accessed by an authorized service provider. Accessing these parts can damage the computer or void the warranty.

---

## Component replacement procedures

This chapter provides removal and replacement procedures for Authorized Service Provider only parts.

There are as many as 74 screws that must be removed, replaced, and/or loosened when servicing the computer. Make special note of each screw size and location during removal and replacement.

### RTC battery

Description	Spare part number
RTC battery (includes cable and double-sided adhesive)	734300-001

Before removing the RTC battery, follow these steps:

1. Turn off the computer. If you are unsure whether the computer is off or in Hibernation, turn the computer on, and then shut it down through the operating system.
2. Disconnect the power from the computer by unplugging the power cord from the computer.
3. Disconnect all external devices from the computer.
4. Remove the battery (see [Battery on page 50](#)).
5. Remove the service cover (see [Service cover on page 51](#)).

Remove the RTC battery:

1. Disconnect the RTC battery cable **(1)** from the system board.

2. Detach the RTC battery **(2)** from the base enclosure. (The RTC battery is attached to the base enclosure with double-sided adhesive.)

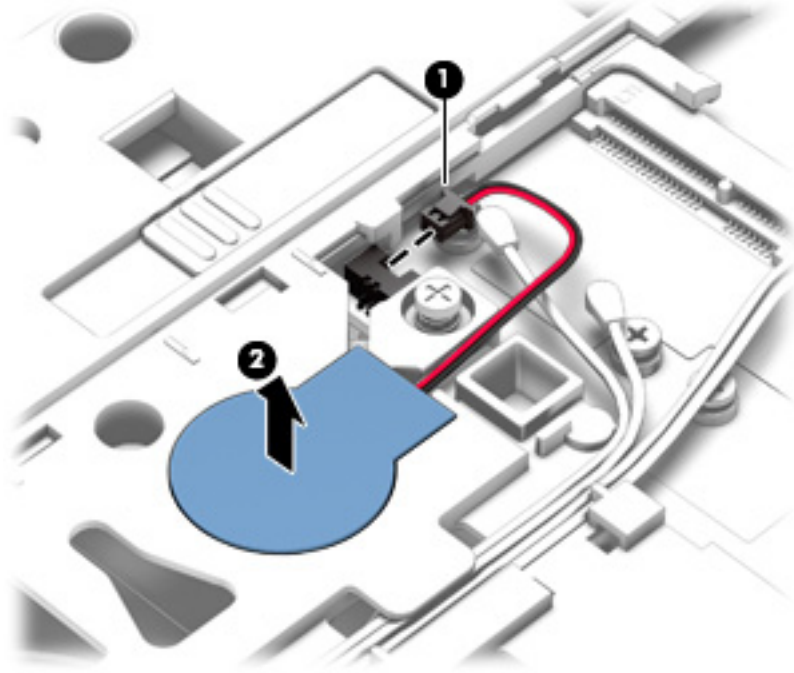

3. Remove the RTC battery and cable.

Reverse this procedure to install the RTC battery.

## Top cover

Description	Spare part number
Top cover (includes TouchPad, TouchPad cable, and TouchPad bracket)	734281-001

Before removing the top cover, follow these steps:

1. Turn off the computer. If you are unsure whether the computer is off or in Hibernation, turn the computer on, and then shut it down through the operating system.
2. Disconnect the power from the computer by unplugging the power cord from the computer.
3. Disconnect all external devices from the computer.
4. Remove the battery (see [Battery on page 50](#)), and then remove the following components:
  - a. Service cover (see [Service cover on page 51](#))
  - b. Hard drive (see [Hard drive on page 52](#))
  - c. Optical drive (see [Optical drive on page 54](#))
  - d. Keyboard (see [Keyboard on page 62](#))

 **NOTE:** When replacing the top cover, be sure to remove the following components from the defective top cover and install them on the replacement top cover:

- Function button board (see [Function button board on page 77](#))
- Power button board (see [Power button board on page 79](#))
- Fingerprint reader board (see [Fingerprint reader board on page 75](#))

Remove the top cover:

1. Close the computer.
2. Turn the computer upside down with the front toward you.

3. Remove the eight Torx T8M2.5×6.5 screws that secure the top cover to the computer.

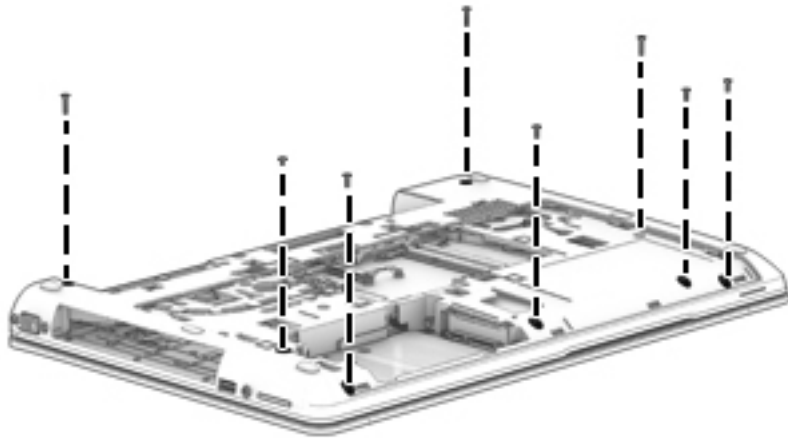

4. Remove the following screws that secure the top cover to the computer:

- (1) Three Torx T8M2.5×4.5 screws in the optical drive bay
- (2) Four Torx T8M2.5×4.5 screws in the battery bay
- (3) Two Phillips PM2.0×3.0 screws in the hard drive bay

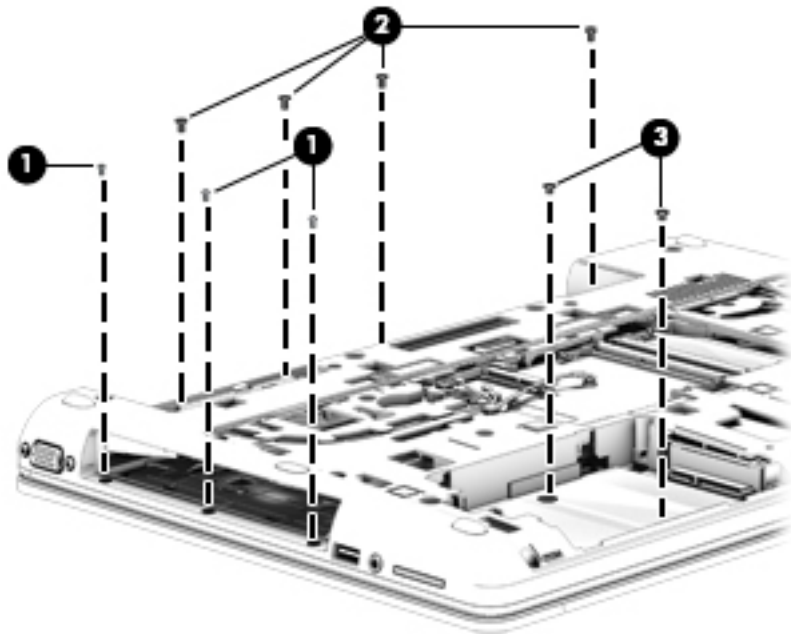

5. Turn the computer right side up with the front toward you.
6. Open the computer.
7. Release the ZIF connector (1) to which the power button board cable is attached, and then disconnect the power button board cable from the system board.
8. Release the ZIF connector (2) to which the function button board cable is attached, and then disconnect the function button board cable from the system board.



9. Remove the Torx T8M2.5×6.5 screw **(3)** that secures the top cover to the computer.

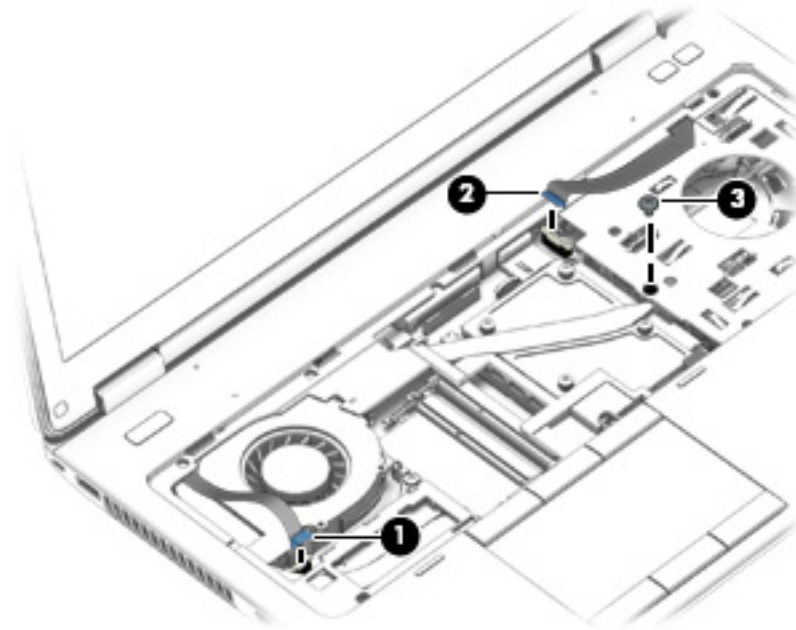

10. Lift the rear edge of the top cover **(1)** until the left and right sides and the front edge detach from the computer.
11. Slide the top cover **(2)** forward until the fingerprint reader board cable and the TouchPad cable are accessible.
12. Release the ZIF connector to which the fingerprint reader board cable is attached, and then disconnect the fingerprint reader board cable **(3)** from the system board.
13. Release the ZIF connector to which the TouchPad cable is attached, and then disconnect the TouchPad cable **(4)** from the system board.

14. Remove the top cover (5).

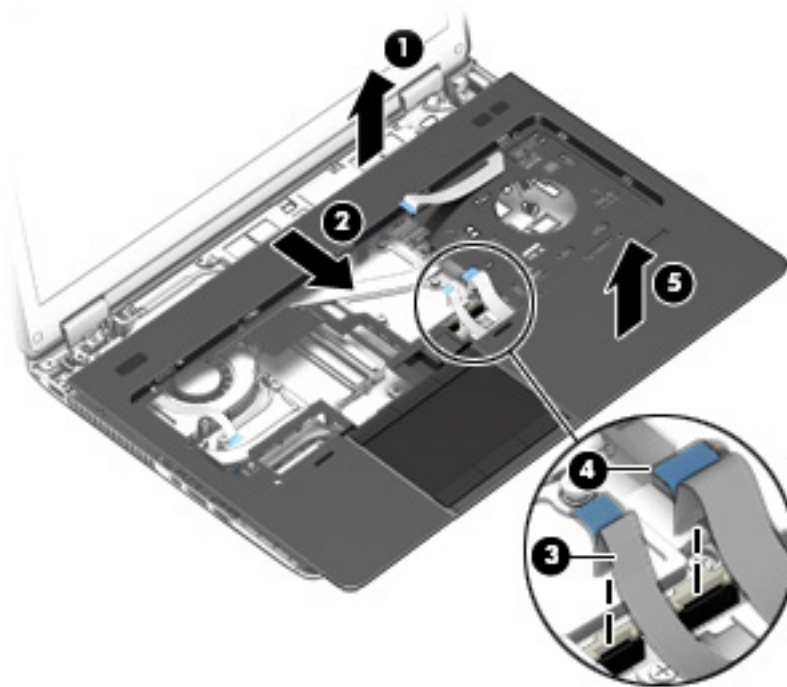

Reverse this procedure to install the top cover.

# Fingerprint reader board

Description	Spare part number
Fingerprint reader board (includes cable and double-sided adhesive)	734286-001

Before removing the fingerprint reader board, follow these steps:

1. Turn off the computer. If you are unsure whether the computer is off or in Hibernation, turn the computer on, and then shut it down through the operating system.
2. Disconnect the power from the computer by unplugging the power cord from the computer.
3. Disconnect all external devices from the computer.
4. Remove the battery (see [Battery on page 50](#)), and then remove the following components:
  - a. Service cover (see [Service cover on page 51](#))
  - b. Hard drive (see [Hard drive on page 52](#))
  - c. Optical drive (see [Optical drive on page 54](#))
  - d. Keyboard (see [Keyboard on page 62](#))
  - e. Top cover (see [Top cover on page 71](#))

Remove the fingerprint reader board:

1. Turn the top cover upside down with the front toward you.
2. Remove the Phillips PM2.0×3.0 screw **(1)** that secures the fingerprint reader board and bracket to the top cover.
3. Slide the fingerprint reader board **(2)** bracket forward and remove it.

The fingerprint reader board bracket is available in the Bracket Kit, spare part number 734299-001.
4. Detach the fingerprint reader board cable **(3)** from the top cover. (The fingerprint reader board cable is attached to the top cover with double-sided adhesive.)

5. Remove the fingerprint reader board **(4)** and cable.

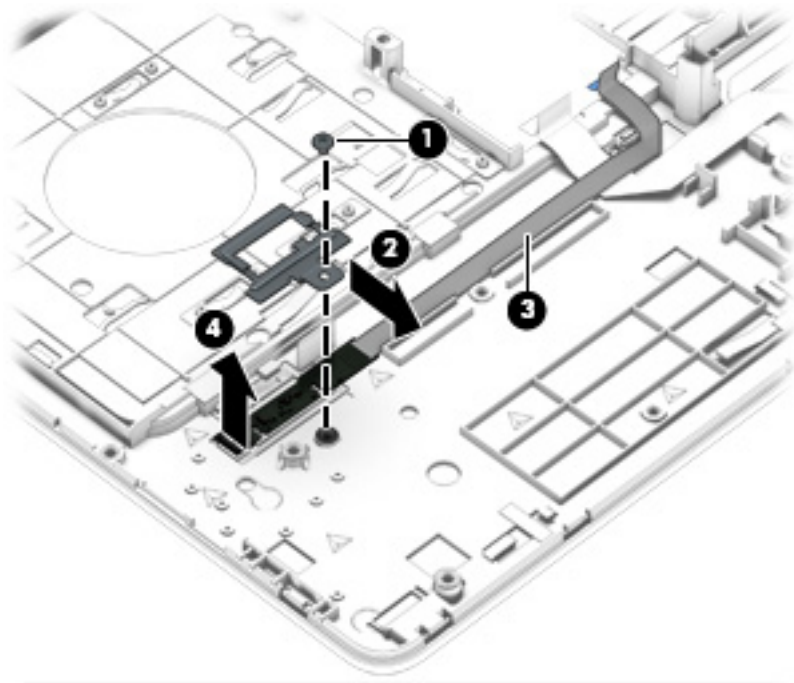

Reverse this procedure to install the fingerprint reader board.

## Function button board

Description	Spare part number
Function button board (includes cable and double-sided adhesive)	734284-001

Before removing the function button board, follow these steps:

1. Turn off the computer. If you are unsure whether the computer is off or in Hibernation, turn the computer on, and then shut it down through the operating system.
2. Disconnect the power from the computer by unplugging the power cord from the computer.
3. Disconnect all external devices from the computer.
4. Remove the battery (see [Battery on page 50](#)), and then remove the following components:
  - a. Service cover (see [Service cover on page 51](#))
  - b. Hard drive (see [Hard drive on page 52](#))
  - c. Optical drive (see [Optical drive on page 54](#))
  - d. Keyboard (see [Keyboard on page 62](#))
  - e. Top cover (see [Top cover on page 71](#))

Remove the function button board:

1. Detach the function button board cable from the top cover. (The function button board cable is attached to the top cover with double-sided adhesive.)

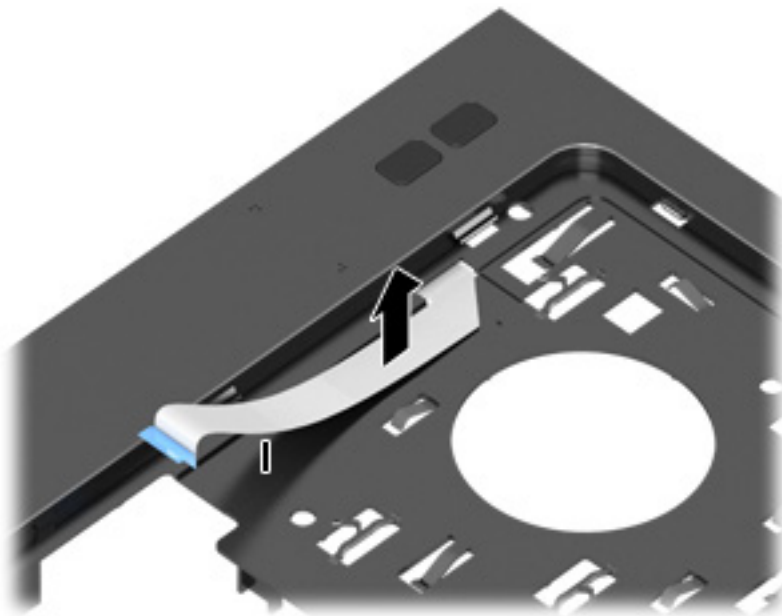

2. Turn the top cover upside down, with the front toward you.

3. Release the function button board cable through the opening **(1)** in the top cover.
4. Remove the Phillips PM2.0x3.0 screw **(2)** that secures the function button board to the top cover.
5. Lift the right side of the function button board **(3)** until it rests at an angle.
6. Remove the function button board **(4)** by sliding it up and to the right at an angle.

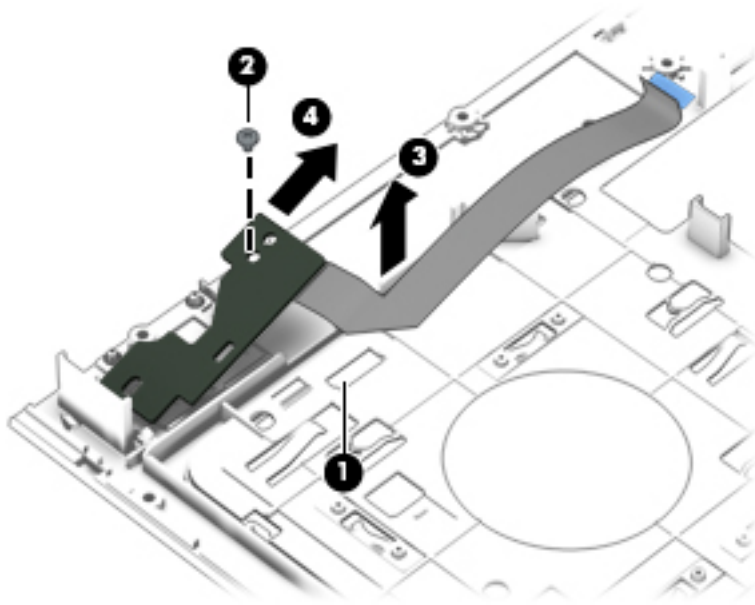

Reverse this procedure to install the function button board.

## Power button board

Description	Spare part number
Power button board (includes cable)	734285-001

Before removing the power button board, follow these steps:

1. Turn off the computer. If you are unsure whether the computer is off or in Hibernation, turn the computer on, and then shut it down through the operating system.
2. Disconnect the power from the computer by unplugging the power cord from the computer.
3. Disconnect all external devices from the computer.
4. Remove the battery (see [Battery on page 50](#)), and then remove the following components:
  - a. Service cover (see [Service cover on page 51](#))
  - b. Hard drive (see [Hard drive on page 52](#))
  - c. Optical drive (see [Optical drive on page 54](#))
  - d. Keyboard (see [Keyboard on page 62](#))
  - e. Top cover (see [Top cover on page 71](#))

Remove the power button board:

1. Turn the top cover upside down, with the front toward you.
2. Remove the Phillips PM2.0×3.0 screw **(1)** that secures the power button board to the top cover.
3. Release the clips **(2)** that secure the power button board to the top cover.

4. Remove the power button board **(3)** and cable

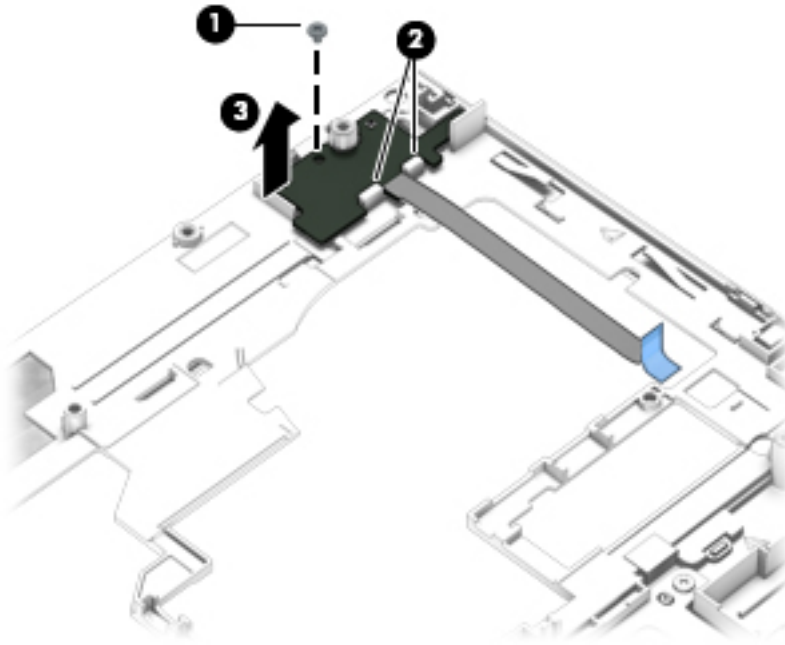

Reverse this procedure to install the power button board.



## ExpressCard assembly

Description	Spare part number
ExpressCard assembly (includes activity LEDs and Thunderbolt port, Dual Mode DisplayPort, and USB port)	734287-001

Before removing the ExpressCard assembly, follow these steps:

1. Turn off the computer. If you are unsure whether the computer is off or in Hibernation, turn the computer on, and then shut it down through the operating system.
2. Disconnect the power from the computer by unplugging the power cord from the computer.
3. Disconnect all external devices from the computer.
4. Remove the battery (see [Battery on page 50](#)), and then remove the following components:
  - a. Service cover (see [Service cover on page 51](#))
  - b. Hard drive (see [Hard drive on page 52](#))
  - c. Optical drive (see [Optical drive on page 54](#))
  - d. Keyboard (see [Keyboard on page 62](#))
  - e. Top cover (see [Top cover on page 71](#))

Remove the ExpressCard assembly:

1. Remove the Torx T8M2.5×4.5 screw **(1)** that secures the system lens to the base enclosure.
2. Remove the system lens **(2)**.

The system lens is available in the Plastics Kit, spare part number 734297-001.

3. Remove the three Torx T8M2.5×4.5 screws **(3)** that secure the ExpressCard assembly to the base enclosure.

4. Disconnect the ExpressCard assembly (4) from the system board by lifting up on the right side of the assembly.

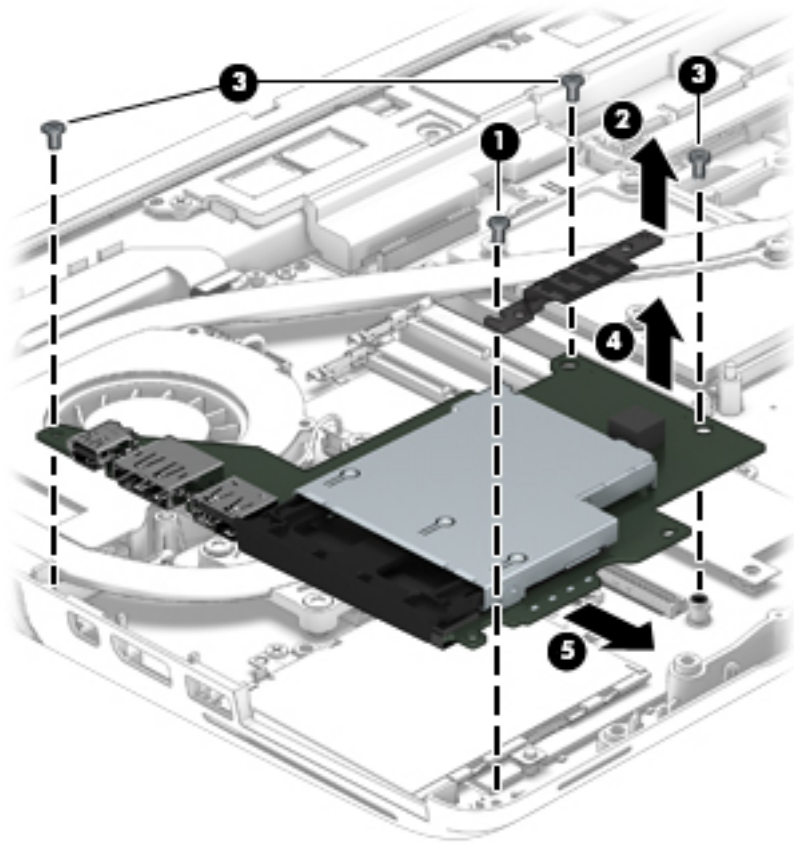

5. Remove the the ExpressCard assembly.

Reverse this procedure to install the ExpressCard assembly.

## Smart card reader

Description	Spare part number
Smart card reader (includes cable)	742159-001

Before removing the smart card reader, follow these steps:

1. Turn off the computer. If you are unsure whether the computer is off or in Hibernation, turn the computer on, and then shut it down through the operating system.
2. Disconnect the power from the computer by unplugging the power cord from the computer.
3. Disconnect all external devices from the computer.
4. Remove the battery (see [Battery on page 50](#)), and then remove the following components:
  - a. Service cover (see [Service cover on page 51](#))
  - b. Hard drive (see [Hard drive on page 52](#))
  - c. Optical drive (see [Optical drive on page 54](#))
  - d. Keyboard (see [Keyboard on page 62](#))
  - e. Top cover (see [Top cover on page 71](#))
  - f. ExpressCard assembly (see [ExpressCard assembly on page 81](#))

Remove the smart card reader:

1. Release the ZIF connector **(1)** to which the smart card reader cable is attached, and then disconnect the smart card reader cable from the system board.
2. Remove the two Torx T8M2.5×4.5 screws **(2)** that secure the smart card reader to the base enclosure.

3. Remove the smart card reader (3).

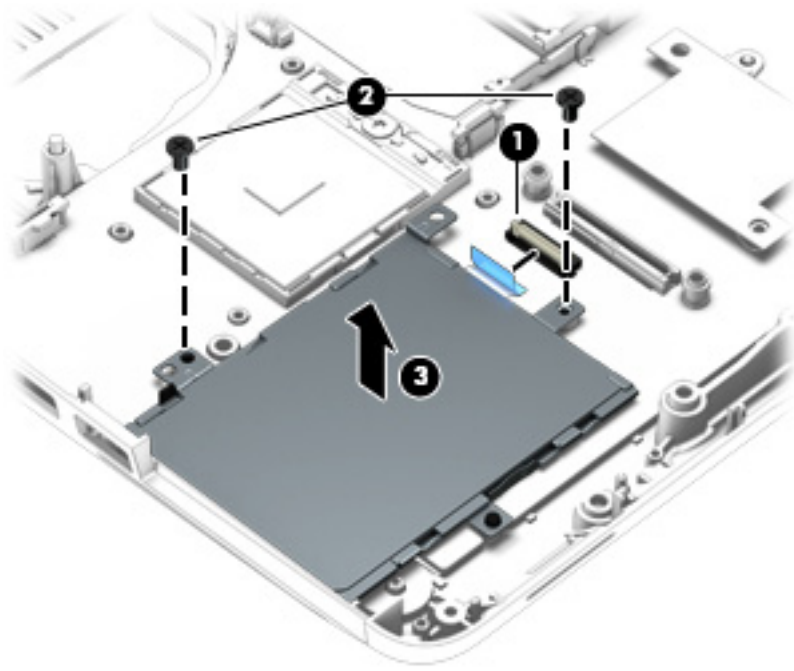

Reverse this procedure to install the smart card reader and cable.

## Audio/USB board

Description	Spare part number
Audio/USB board (includes SD Card reader)	734288-001

Before removing the audio/USB board, follow these steps:

1. Turn off the computer. If you are unsure whether the computer is off or in Hibernation, turn the computer on, and then shut it down through the operating system.
2. Disconnect the power from the computer by unplugging the power cord from the computer.
3. Disconnect all external devices from the computer.
4. Remove the battery (see [Battery on page 50](#)), and then remove the following components:
  - a. Service cover (see [Service cover on page 51](#))
  - b. Hard drive (see [Hard drive on page 52](#))
  - c. Optical drive (see [Optical drive on page 54](#))
  - d. Keyboard (see [Keyboard on page 62](#))
  - e. Top cover (see [Top cover on page 71](#))

Remove the audio/USB board:

1. Remove the four Torx T8M2.5×4.5 screws **(1)** that secure the audio/USB board to the base enclosure.

2. Disconnect the audio/USB board **(2)** from the system board by lifting up on the left side of the audio/USB board.

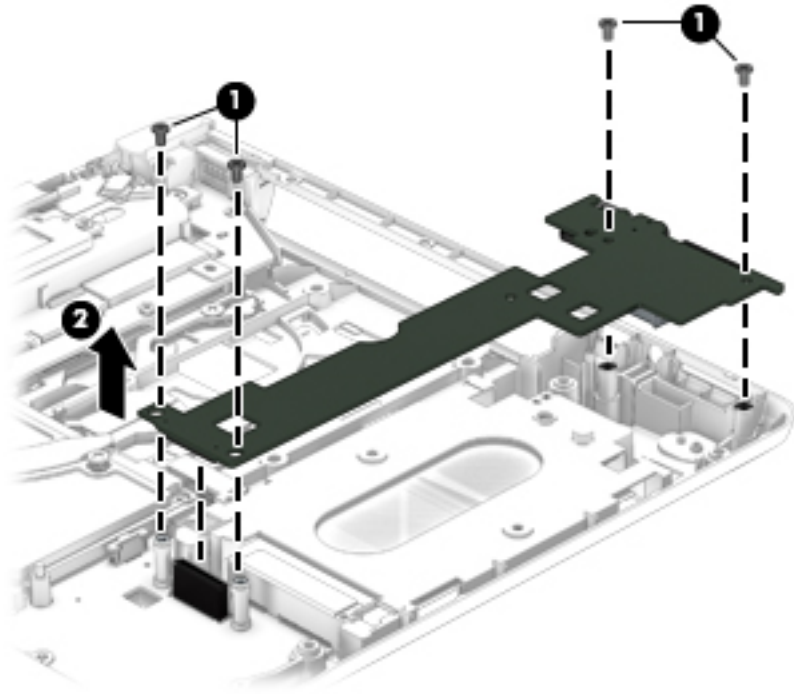

3. Remove the audio/USB board.

Reverse this procedure to install the audio/USB board.

## USB board

Description	Spare part number
USB board (includes cable and double-sided adhesive)	734293-001

Before removing the USB board, follow these steps:

1. Turn off the computer. If you are unsure whether the computer is off or in Hibernation, turn the computer on, and then shut it down through the operating system.
2. Disconnect the power from the computer by unplugging the power cord from the computer.
3. Disconnect all external devices from the computer.
4. Remove the battery (see [Battery on page 50](#)), and then remove the following components:
  - a. Service cover (see [Service cover on page 51](#))
  - b. Hard drive (see [Hard drive on page 52](#))
  - c. Optical drive (see [Optical drive on page 54](#))
  - d. Keyboard (see [Keyboard on page 62](#))
  - e. Top cover (see [Top cover on page 71](#))

Remove the USB board:

1. Release the ZIF connector **(1)** to which the USB board cable is attached, and then disconnect the USB board cable from the system board.
2. Detach the USB board cable **(2)** from the base enclosure. (The USB board cable is attached to the base enclosure with double-sided adhesive.)

3. Remove the Torx T8M2.5x4.5 screw **(3)** that secures the USB board to the base enclosure.

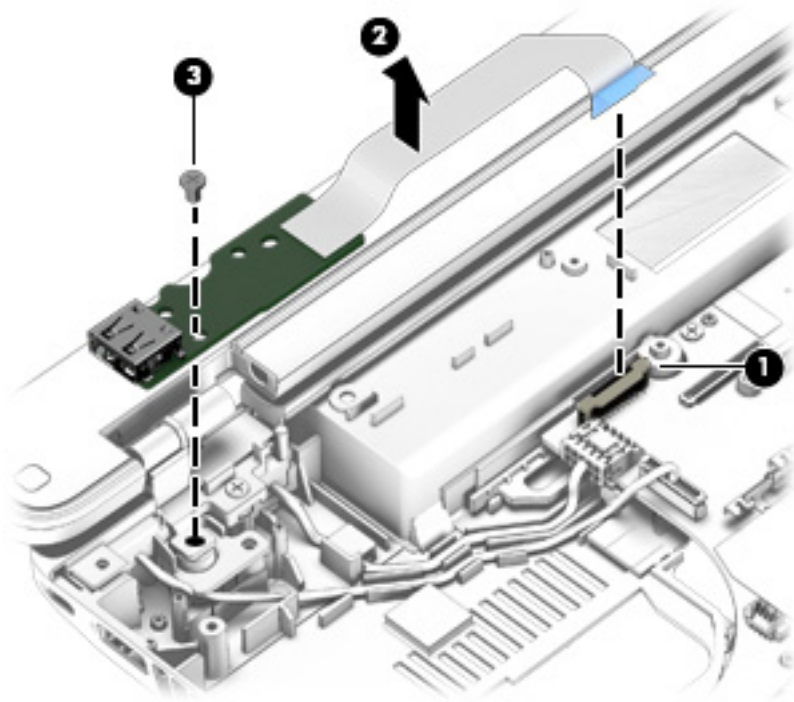

4. Remove the USB board and cable.

Reverse this procedure to install the USB board.



# Speakers

Description	Spare part number
Speakers (includes cable)	734292-001

Before removing the speakers, follow these steps:

1. Turn off the computer. If you are unsure whether the computer is off or in Hibernation, turn the computer on, and then shut it down through the operating system.
2. Disconnect the power from the computer by unplugging the power cord from the computer.
3. Disconnect all external devices from the computer.
4. Remove the battery (see [Battery on page 50](#)), and then remove the following components:
  - a. Service cover (see [Service cover on page 51](#))
  - b. Hard drive (see [Hard drive on page 52](#))
  - c. Optical drive (see [Optical drive on page 54](#))
  - d. Keyboard (see [Keyboard on page 62](#))
  - e. Top cover (see [Top cover on page 71](#))

Remove the speakers:

1. Disconnect the speaker cable **(1)** from the system board.
2. Remove the two Phillips PM2.0×3.0 screws **(1)** that secure the speakers to the base enclosure.

3. Remove the speakers (3) and cable.

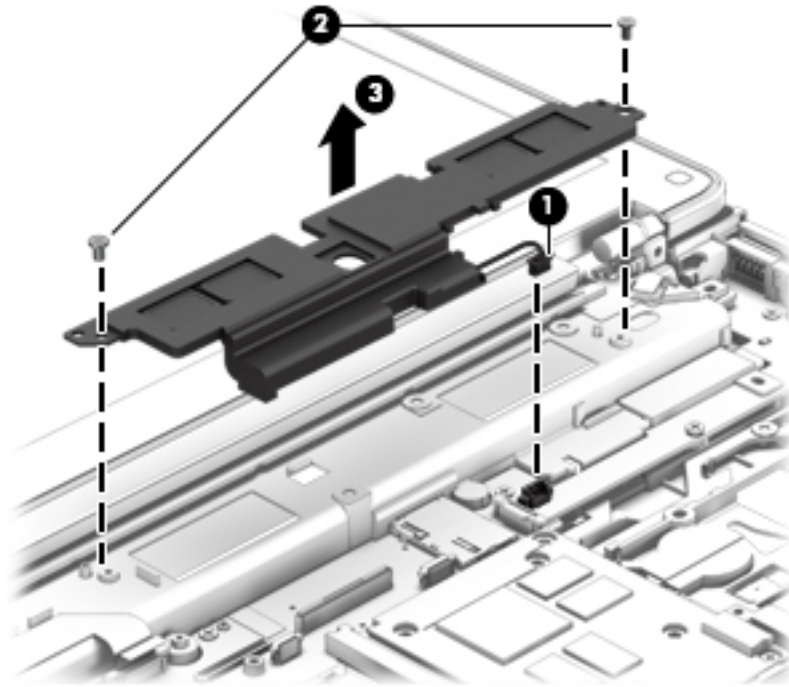

Reverse this procedure to install the speakers.

## Fan/heat sink assembly

 **NOTE:** The fan/heat sink assembly spare part kit includes replacement thermal material.

Description	Spare part number
For use only with an NVIDIA Quadro K1100M NVIDIA N15P-Q1 graphics board, spare part number 734276-001	734289-001
For use only with an NVIDIA Quadro K610M NVIDIA N15M-Q2 graphics board, spare part number 745325-001	734290-001
For use only with an NVIDIA Quadro K2100M NVIDIA N15P-Q3 graphics board, spare part number 734277-001	734291-001

Before removing the fan/heat sink assembly, follow these steps:

1. Turn off the computer. If you are unsure whether the computer is off or in Hibernation, turn the computer on, and then shut it down through the operating system.
2. Disconnect the power from the computer by unplugging the power cord from the computer.

3. Disconnect all external devices from the computer.
4. Remove the battery (see [Battery on page 50](#)), and then remove the following components:
  - a. Service cover (see [Service cover on page 51](#))
  - b. Hard drive (see [Hard drive on page 52](#))
  - c. Optical drive (see [Optical drive on page 54](#))
  - d. Keyboard (see [Keyboard on page 62](#))
  - e. Top cover (see [Top cover on page 71](#))

Remove the fan/heat sink assembly:

1. Disconnect the fan cable **(1)** from the system board.
2. Following the 1 through 4 sequence stamped into the processor heat sink, loosen the four Phillips captive screws **(2)** that secure the processor heat sink to the system board.
3. Following the 5 through 8 sequence stamped into the graphics board heat sink, loosen the four Phillips captive screws **(3)** that secure the graphics board heat sink to the system board.
4. Remove the fan/heat sink assembly **(4)**.

---

 **NOTE:** Due to the adhesive quality of the thermal material located between the fan/heat sink assembly and the system board components, it may be necessary to move the fan/heat sink assembly from side to side to detach it.

---

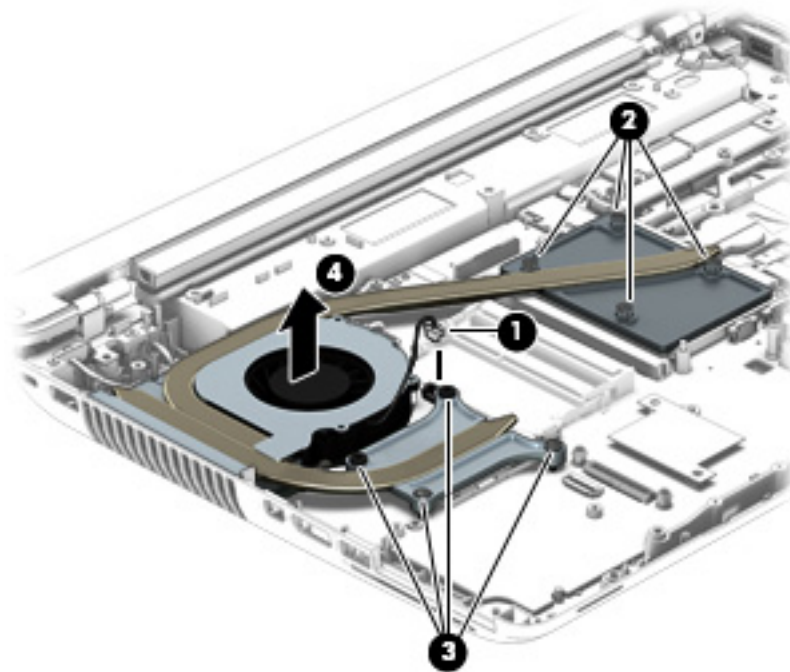

 **NOTE:** The thermal material must be thoroughly cleaned from the surfaces of the fan/heat sink assembly and the system board components each time the fan/heat sink assembly is removed. Replacement thermal material is included with the fan/heat sink assembly, processor, and system board spare part kits.

- Various thermal pads are used on the graphics board components **(1)** and **(7)** and the heat sink sections **(2)** and **(8)** that service them
- Thermal paste is used on the processor **(3)** and the heat sink section **(4)** that services it
- Thermal paste is used on the graphics board processor **(5)** and the heat sink section **(6)** that services it

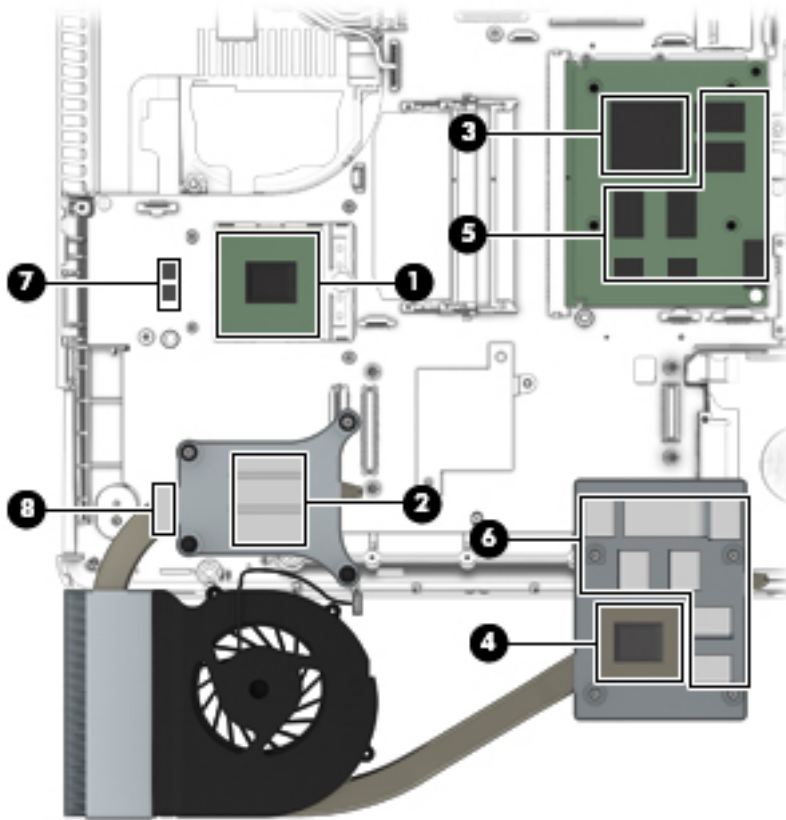

Reverse this procedure to install the fan/heat sink assembly.

## Processor



**NOTE:** The processor spare part kit includes replacement thermal material.

Description	Spare part number
Intel Quad Core i7-4900MQ 2.80-GHz (SC turbo up to 3.80-GHz) processor (1600-MHz FSB, 8.0-MB L3 cache, 47 W)	723523-002
Intel Quad Core i7-4800MQ 2.70-GHz (SC turbo up to 3.70-GHz) processor (1600-MHz FSB, 6.0-MB L3 cache, 47 W)	723524-002
Intel Quad Core i7-4700MQ 2.40-GHz (SC turbo up to 3.40-GHz) processor (1600-MHz FSB, 6.0-MB L3 cache, 47 W)	723521-002
Intel Quad Core i7-4600M 2.90-GHz (SC turbo up to 3.60-GHz) processor (1600-MHz FSB, 4.0-MB L3 cache, 37 W)	737330-002
Intel Dual Core i5-4330M 2.80-GHz (SC turbo up to 3.50-GHz) processor (1600-MHz FSB, 3.0-MB L3 cache, 37 W)	738201-002
Intel Dual Core i5-4300M 2.60-GHz (SC turbo up to 3.30-GHz) processor (1600-MHz FSB, 3.0-MB L3 cache, 37 W)	738309-002

Before removing the processor, follow these steps:

1. Turn off the computer. If you are unsure whether the computer is off or in Hibernation, turn the computer on, and then shut it down through the operating system.
2. Disconnect the power from the computer by unplugging the power cord from the computer.
3. Disconnect all external devices from the computer.
4. Remove the battery (see [Battery on page 50](#)), and then remove the following components:
  - a. Service cover (see [Service cover on page 51](#))
  - b. Hard drive (see [Hard drive on page 52](#))
  - c. Optical drive (see [Optical drive on page 54](#))
  - d. Keyboard (see [Keyboard on page 62](#))
  - e. Top cover (see [Top cover on page 71](#))
  - f. Fan/heat sink assembly (see [Fan/heat sink assembly on page 90](#))

Remove the processor:

1. Use a Torx8 screw driver **(1)** to turn the processor locking screw one-half turn counterclockwise **(2)**, until you hear a click.

2. Lift the processor **(3)** straight up, and remove it.

 **NOTE:** The gold triangle **(4)** on the processor must be aligned with the triangle icon embossed on the processor socket when you install the processor.

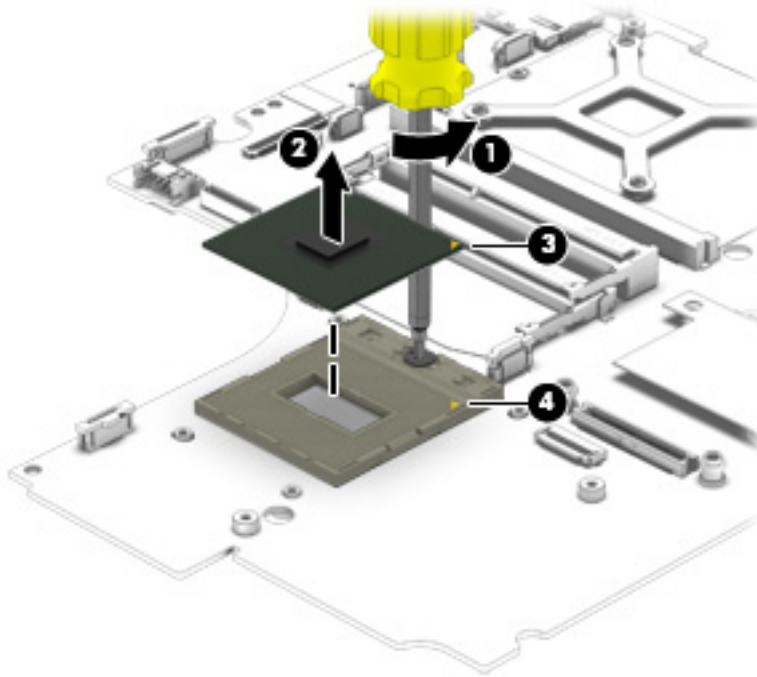

Reverse this procedure to install the processor.

## Graphics board

 **NOTE:** The graphics board spare part kit includes replacement thermal material.

Description	Spare part number
NVIDIA Quadro K1100M NVIDIA N15P-Q1 graphics board	734276-001
NVIDIA Quadro K610M NVIDIA N15M-Q2 graphics board	745325-001
NVIDIA Quadro K2100M NVIDIA N15P-Q3 graphics board	734277-001

Before removing the graphics board, follow these steps:

1. Turn off the computer. If you are unsure whether the computer is off or in Hibernation, turn the computer on, and then shut it down through the operating system.
2. Disconnect the power from the computer by unplugging the power cord from the computer.

3. Disconnect all external devices from the computer.
4. Remove the battery (see [Battery on page 50](#)), and then remove the following components:
  - a. Service cover (see [Service cover on page 51](#))
  - b. Hard drive (see [Hard drive on page 52](#))
  - c. Optical drive (see [Optical drive on page 54](#))
  - d. Keyboard (see [Keyboard on page 62](#))
  - e. Top cover (see [Top cover on page 71](#))
  - f. Fan/heat sink assembly (see [Fan/heat sink assembly on page 90](#))

Remove the graphics board:

1. Remove the two Torx T8M2.5×4.5 screws **(1)** that secure the graphics board to the system board. (The graphics board tilts up.)
2. Remove the graphics board **(2)** by pulling the board away from the slot at an angle.

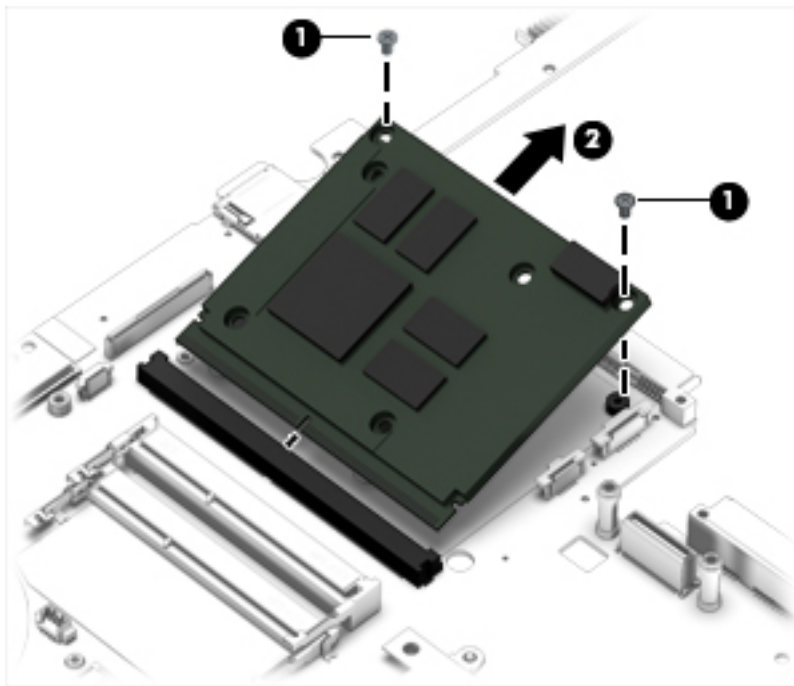

Reverse this procedure to install the graphics board.

## Display assembly



**NOTE:** The DreamVision display assembly is spared as a whole unit assembly only. The LED display assembly is spared at the subcomponent level only. For more LED display assembly spare part information, see the individual removal subsections.

Description	Spare part number
15.6-in, FHD, UWVA, DreamVision display assembly equipped with a webcam	735965-001
15.6-in, FHD, UWVA, DreamVision display assembly not equipped with a webcam	735964-001

To remove the display assembly and access the LED display assembly subcomponents, follow these steps:

1. Turn off the computer. If you are unsure whether the computer is off or in Hibernation, turn the computer on, and then shut it down through the operating system.
2. Disconnect the power from the computer by unplugging the power cord from the computer.
3. Disconnect all external devices from the computer.
4. Remove the battery (see [Battery on page 50](#)), and then remove the following components:
  - a. Service cover (see [Service cover on page 51](#))
  - b. Hard drive (see [Hard drive on page 52](#))
  - c. Optical drive (see [Optical drive on page 54](#))
  - d. Keyboard (see [Keyboard on page 62](#))
  - e. Top cover (see [Top cover on page 71](#))

Remove the display assembly:

1. Close the computer.
2. Turn the computer upside down, with the rear toward you.
3. Make sure that the WWAN antenna cables are disconnected from the WWAN module (see [WWAN module on page 56](#)).
4. Make sure that the WLAN antenna cables are disconnected from the WLAN module (see [WLAN module on page 59](#)).



5. Release the wireless antenna cables **(1)** from the routing clips **(2)** and channels built into the base enclosure.

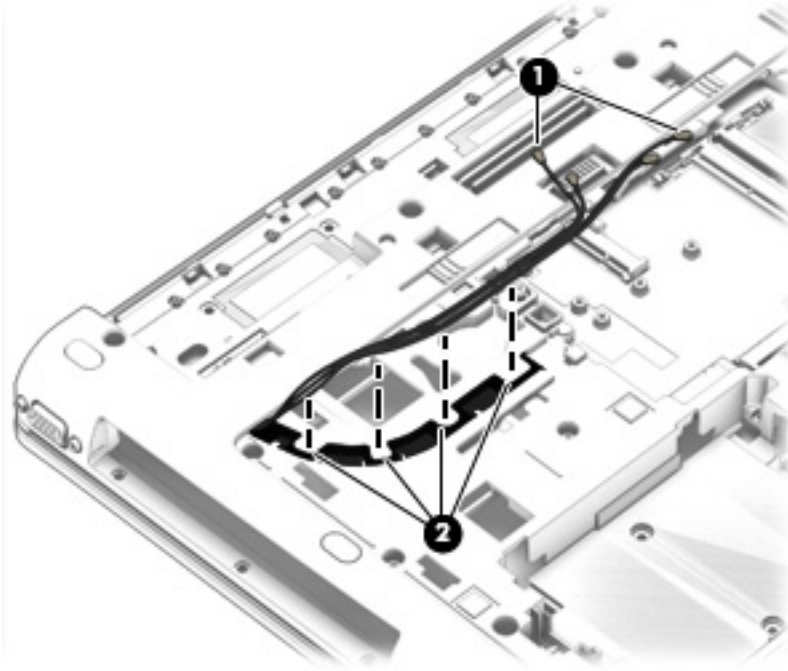

6. Turn the computer right side up, with the rear toward you.
7. Remove the four Torx T8M2.0×3.0 screws **(1)** that secure the hinge cover to the computer.
8. Remove the hinge cover **(2)**.

The hinge cover is available using spare part number 734294-001.

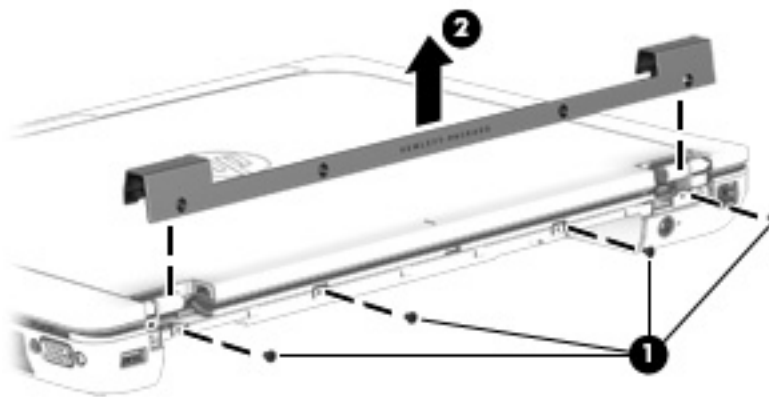

9. Remove the two Torx T8M2.5×4.5 screws that secure the display assembly to the base enclosure.



10. Position the computer with the front toward you.
11. Open the computer as far as it will open.
12. Remove the Phillips PM2.0×3.0 screw **(1)** that secures the display panel cable and bracket to the system board.
13. Remove the display panel cable bracket **(2)**.

The display panel cable bracket is included in the Hinge Kit, spare part number 738311-001.

14. Disconnect the display panel cable **(3)** from the system board.
15. Detach the display panel cable **(4)** from the base enclosure. (The display panel cable is attached to the base enclosure with double-sided adhesive.)

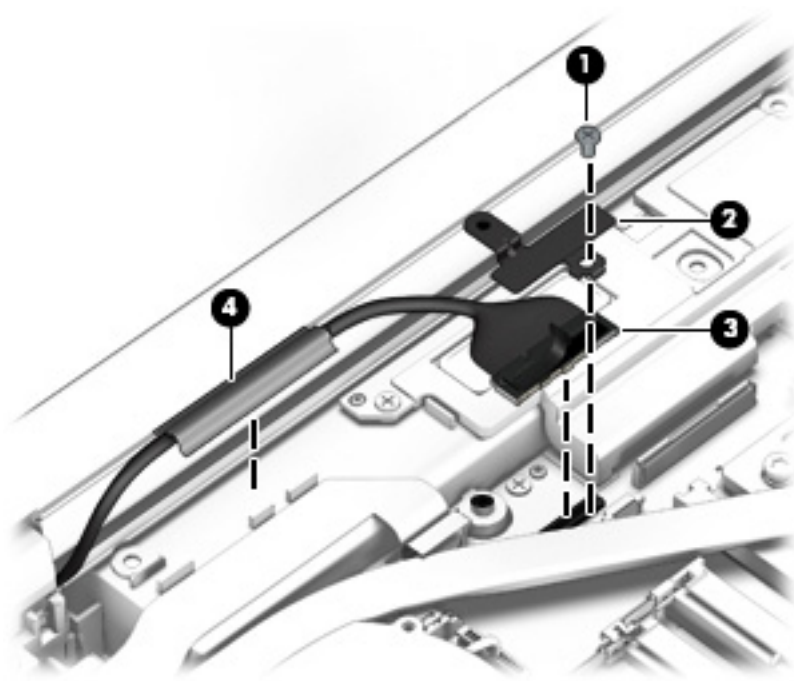

16. Release the wireless antenna cables from the routing channels built into the base enclosure.

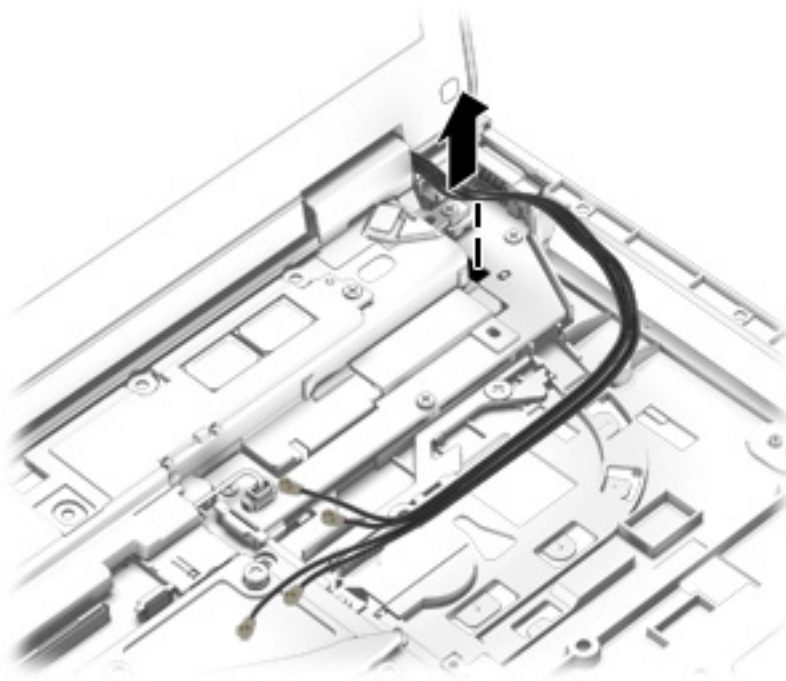

17. Remove the two Torx T8M2.5×6.5 screws (1) that secure the display assembly to the base enclosure.

18. Remove the display assembly (2).

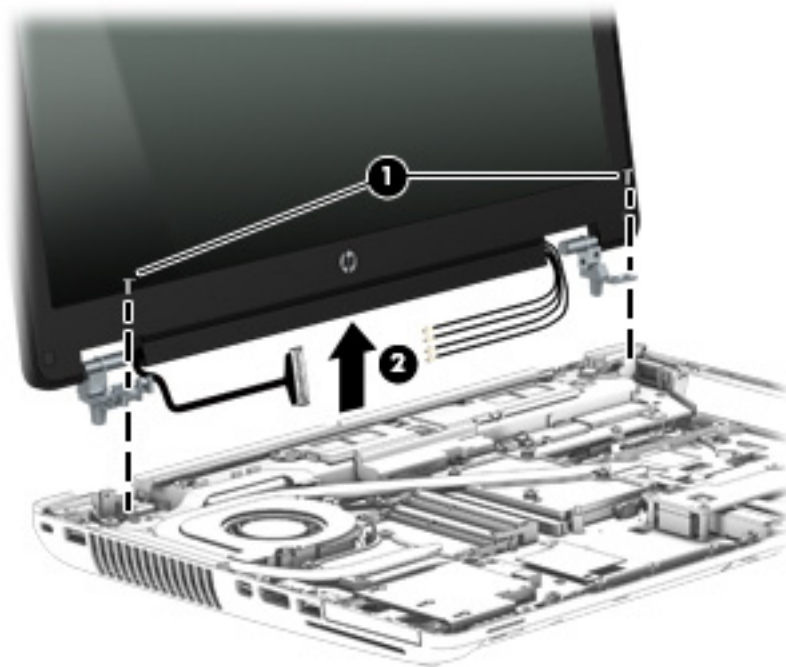

---

 **NOTE:** Steps 19 through 22 apply only to LED display assemblies.

---

- 19.** If it is necessary to replace the display bezel or any of the LED display assembly subcomponents:
- a.** Remove the two screw covers **(1)** and the two Phillips PM2.0x5.5 screws **(2)** that secure the display bezel to the display assembly.

The screw covers are available in all LED display assembly subcomponent spare part kits.

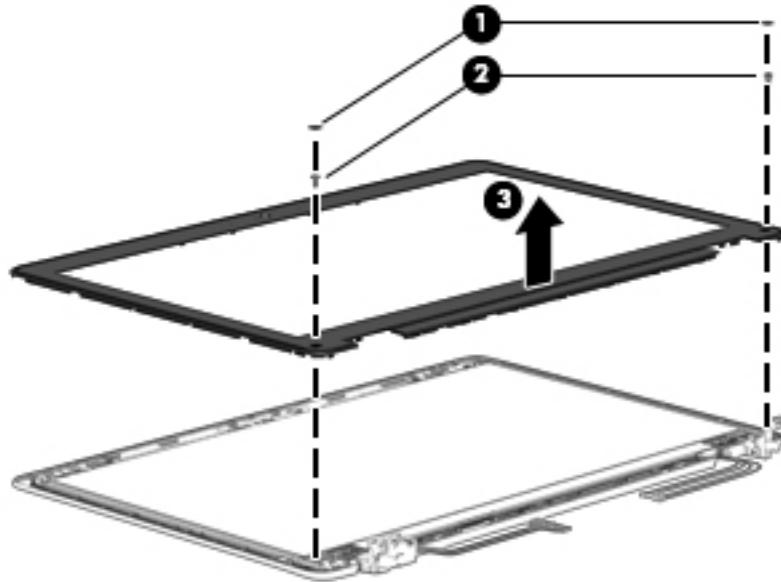

- b.** Flex the inside edges of the top edge **(1)**, the left and right sides **(2)**, and the bottom edge **(3)** of the display bezel until the bezel disengages from the display enclosure.
- c.** Remove the display bezel **(4)**.

The display bezel is available using spare part numbers 734301-001 (for use only on computer models equipped with a webcam) and 734302-001 (for use only on computer models not equipped with a webcam).

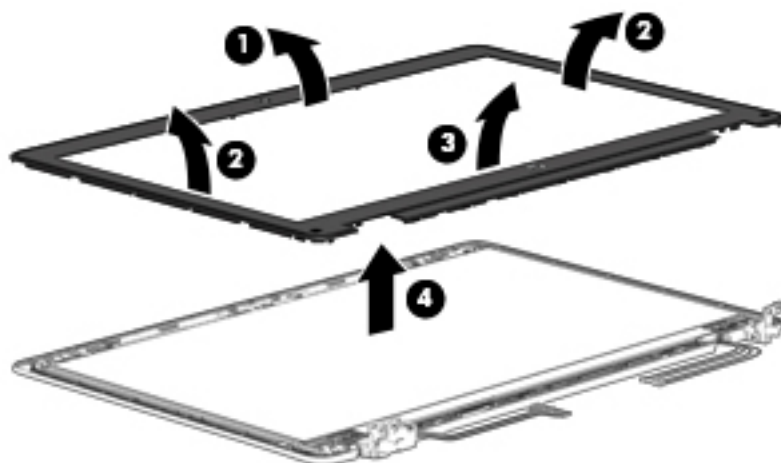

**20.** If it is necessary to replace the display panel:

- a.** Remove the four Phillips PM2.0×3.0 screws that secure the display panel to the display enclosure.

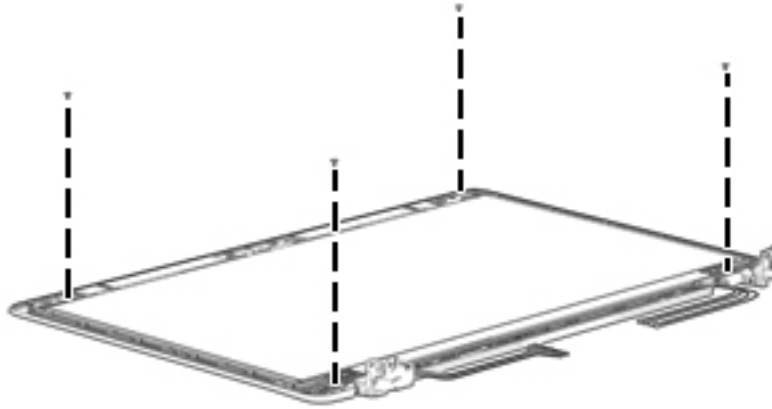

**⚠ CAUTION:** Before turning the display panel upside down, make sure the work surface is clear of tools, screws, and any other foreign objects. Failure to follow this caution can result in damage to the display panel.

- b.** Lift the top edge of the display panel **(1)** and swing it up and forward until it rests upside down in front of the display enclosure.
- c.** Release the adhesive strip **(2)** that secures the display panel cable connector to the display panel.
- d.** Disconnect the display panel cable **(3)** from the display panel.

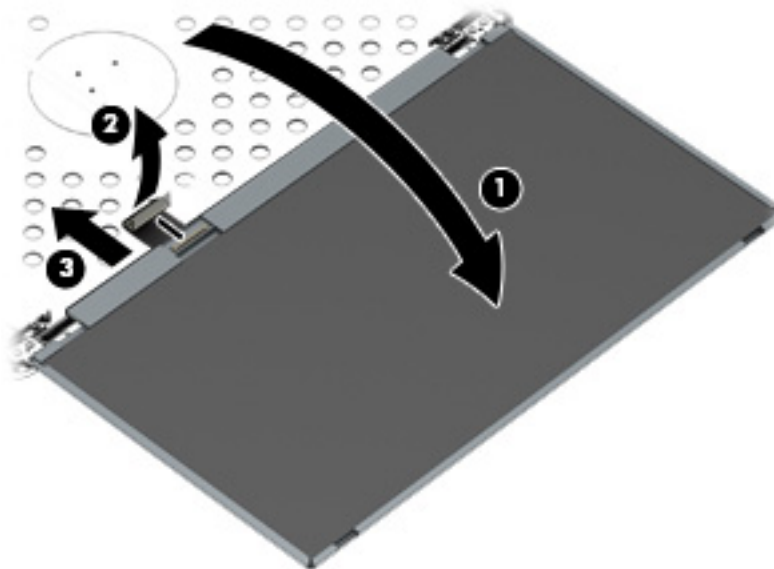

- e.** Remove the display panel.

The display panel is available using spare part numbers 735607-001 (15.6-in, FHD, UWVA, LED display panel) and 735604-001 (15.6-in, FHD, SVA, LED display panel).

**21.** If it is necessary to replace the webcamera/microphone module or microphone module:

**⚠ CAUTION:** Handle the webcamera/microphone module and microphone module with caution. These modules have a thin profile and are susceptible to damage when not handled carefully.

- a. Disconnect the webcamera/microphone module cable **(1)** from the webcamera/microphone module.
- b. Detach the webcamera/microphone module **(2)** from the display enclosure. (The webcamera/microphone module is attached to the display enclosure with double-sided adhesive.)

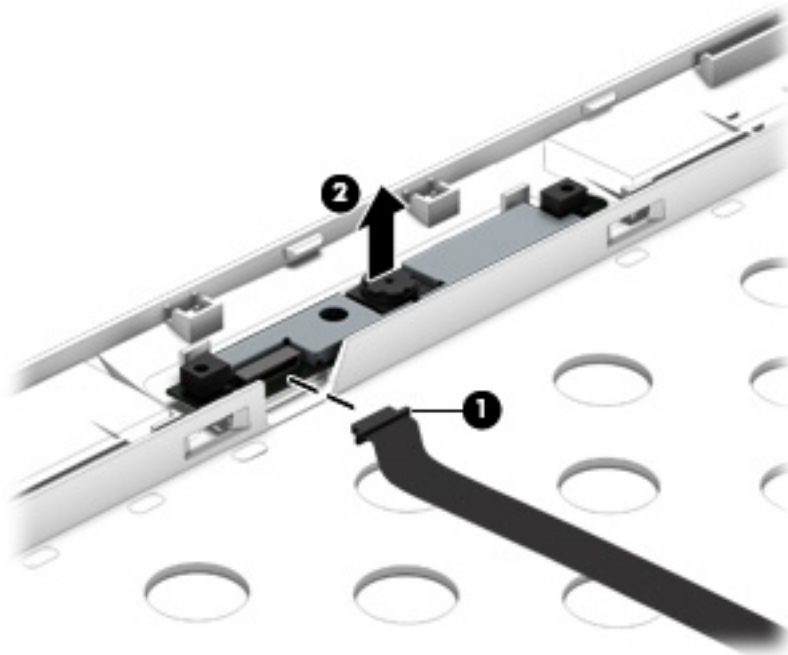

- c. Remove the webcamera/microphone module.

The webcamera/microphone module is available using spare part number 734295-001. The microphone module is available using spare part number 735370-001.

**22.** If it is necessary to replace the display hinges:

- a. Remove the four Torx T8M2.5×4.5 screws **(1)** that secure the display hinges to the display panel.

- b. Remove the display hinges (2).

The display hinges are available using spare part number 738311-001 and include the left and right hinges.

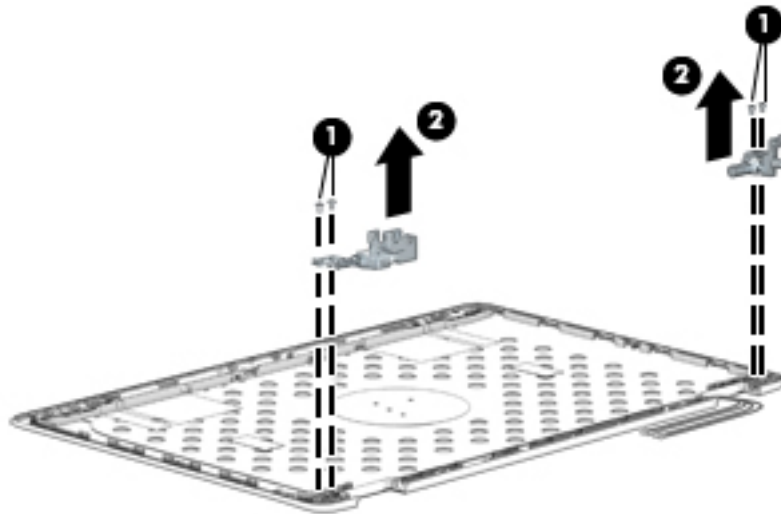

Reverse this procedure to reassemble and install the display assembly.

## System board

 **NOTE:** The system board spare part kit includes battery connector bracket and replacement thermal material.

Description	Spare part number
For use only on computer models equipped with an Intel Quad Core processor and the Windows 8 Professional operating system	734304-601
For use only on computer models equipped with an Intel Quad Core processor and the Windows 8 Standard operating system	734304-501
For use only on computer models equipped with an Intel Quad Core processor and the Linux operating system	734304-001
For use only on computer models equipped with an Intel Dual Core processor and the Windows 8 Professional operating system	734303-601
For use only on computer models equipped with an Intel Dual Core processor and the Windows 8 Standard operating system	734303-501
For use only on computer models equipped with an Intel Dual Core processor and the Linux operating system	734303-001

Before removing the system board, follow these steps:

1. Turn off the computer. If you are unsure whether the computer is off or in Hibernation, turn the computer on, and then shut it down through the operating system.
2. Disconnect the power from the computer by unplugging the power cord from the computer.
3. Disconnect all external devices from the computer.
4. Remove the battery (see [Battery on page 50](#)), and then remove the following components:
  - a. Service cover (see [Service cover on page 51](#))
  - b. Hard drive (see [Hard drive on page 52](#))
  - c. Optical drive (see [Optical drive on page 54](#))
  - d. Keyboard (see [Keyboard on page 62](#))
  - e. Top cover (see [Top cover on page 71](#))
  - f. ExpressCard assembly (see [ExpressCard assembly on page 81](#))
  - g. Audio/USB board (see [Audio/USB board on page 85](#))
  - h. Speakers (see [Speakers on page 89](#))
  - i. Fan/heat sink assembly (see [Fan/heat sink assembly on page 90](#))
  - j. Display assembly (see [Display assembly on page 96](#))



---

**NOTE:** When replacing the system board, be sure that the following components are removed from the defective system board and installed on the replacement system board:

---

- WWAN module (see [WWAN module on page 56](#))
- Solid-state drive (see [Solid-state drive on page 58](#))
- WLAN module (see [WLAN module on page 59](#))
- Expansion memory (see [Primary memory module on page 61](#))
- Primary memory (see [Expansion memory module on page 67](#))
- smart card reader (see [Smart card reader on page 83](#))
- Processor (see [Processor on page 93](#))
- Graphics board (see [Graphics board on page 94](#))

Remove the system board:

1. Make sure that the RTC battery cable is disconnected from the system board (see [RTC battery on page 69](#)).



2. Disconnect the following cables from the system board:
  - (1) Power connector cable
  - (2) RJ-45 (network) cable
  - (3) USB board cable

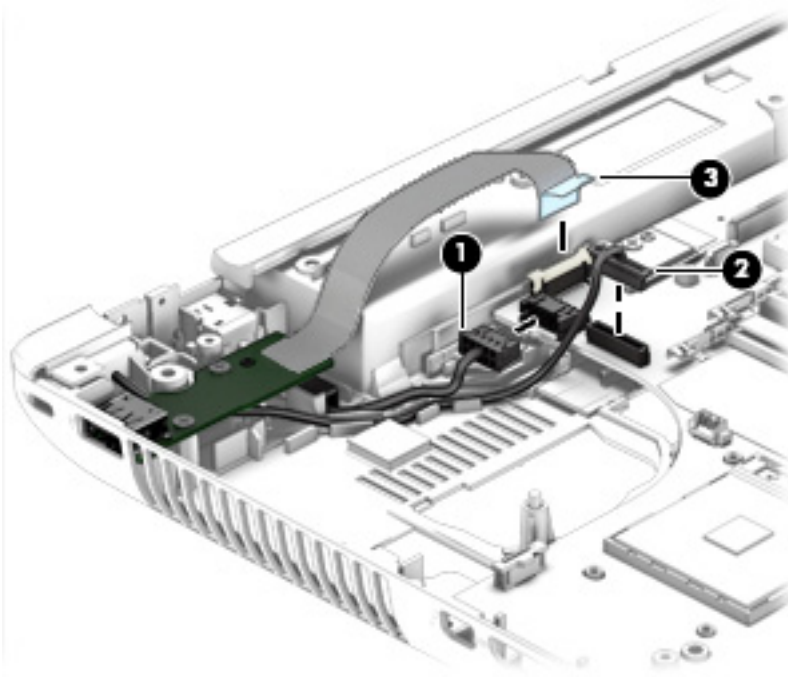

3. Remove the right-side rear corner cover (1).

The right-side rear corner cover is included in the Hinge Cover Kit, spare part number 734294-001.

4. Remove the seven Torx T8M2.5×4.5 screws **(2)** that secure the system board to the base enclosure.

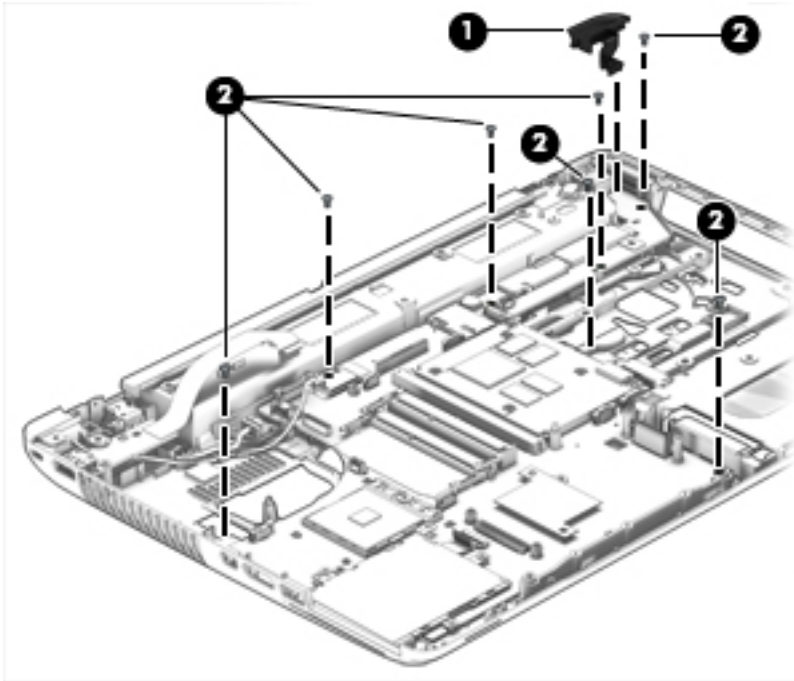

5. Lift up on the left side of the system board **(1)** until it rests at an angle.
6. Remove the system board **(2)** by sliding it up and to the left at an angle.

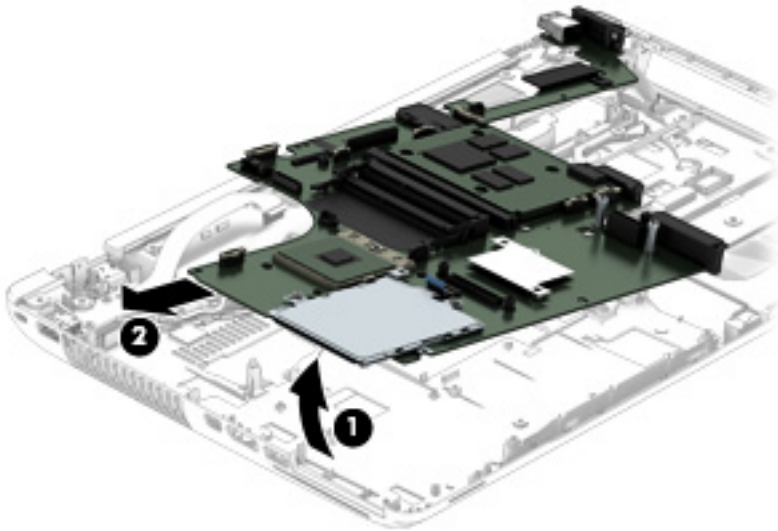

Reverse this procedure to install the system board.

## Power connector cable



**NOTE:** The power connector cable is included in the Cable Kit, spare part number 734283-001.

Before removing the power connector cable, follow these steps:

1. Turn off the computer. If you are unsure whether the computer is off or in Hibernation, turn the computer on, and then shut it down through the operating system.
2. Disconnect the power from the computer by unplugging the power cord from the computer.
3. Disconnect all external devices from the computer.
4. Remove the battery (see [Battery on page 50](#)), and then remove the following components:
  - a. Service cover (see [Service cover on page 51](#))
  - b. Hard drive (see [Hard drive on page 52](#))
  - c. Optical drive (see [Optical drive on page 54](#))
  - d. Keyboard (see [Keyboard on page 62](#))
  - e. Top cover (see [Top cover on page 71](#))
  - f. ExpressCard assembly (see [ExpressCard assembly on page 81](#))
  - g. Audio/USB board (see [Audio/USB board on page 85](#))
  - h. USB board (see [USB board on page 87](#))
  - i. Speakers (see [Speakers on page 89](#))
  - j. Fan/heat sink assembly (see [Fan/heat sink assembly on page 90](#))
  - k. Display assembly (see [Display assembly on page 96](#))

Remove the power connector cable:

1. Disconnect the power connector cable **(1)** from the system board.
2. Release the power connector cable **(2)** from the clips built into the base enclosure.

3. Release the power connector **(3)** from the clips and mold built into the base enclosure.

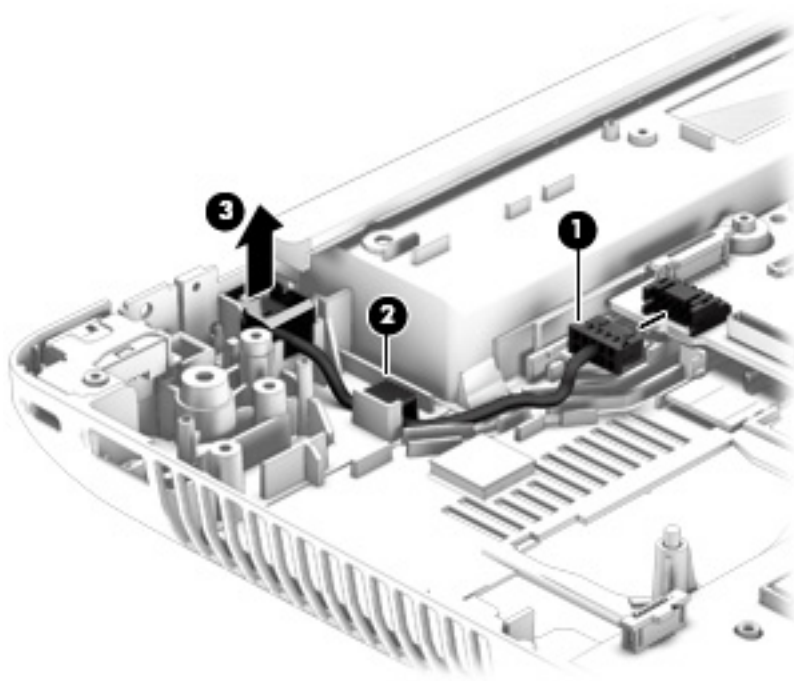

4. Remove the power connector cable.

Reverse this procedure to install the power connector cable.

## RJ-45 (network) cable

 **NOTE:** The RJ-45 (network) cable is included in the Cable Kit, spare part number 734283-001.

---

Before removing the RJ-45 (network) cable, follow these steps:

1. Turn off the computer. If you are unsure whether the computer is off or in Hibernation, turn the computer on, and then shut it down through the operating system.
2. Disconnect the power from the computer by unplugging the power cord from the computer.
3. Disconnect all external devices from the computer.
4. Remove the battery (see [Battery on page 50](#)), and then remove the following components:
  - a. Service cover (see [Service cover on page 51](#))
  - b. Hard drive (see [Hard drive on page 52](#))
  - c. Optical drive (see [Optical drive on page 54](#))
  - d. Keyboard (see [Keyboard on page 62](#))
  - e. Top cover (see [Top cover on page 71](#))
  - f. ExpressCard assembly (see [ExpressCard assembly on page 81](#))
  - g. Audio/USB board (see [Audio/USB board on page 85](#))
  - h. USB board (see [USB board on page 87](#))
  - i. Speakers (see [Speakers on page 89](#))
  - j. Fan/heat sink assembly (see [Fan/heat sink assembly on page 90](#))
  - k. Display assembly (see [Display assembly on page 96](#))

Remove the RJ-45 (network) cable:

1. Remove the Phillips PM2.0×5.5 screw **(1)** that secures the left-side rear corner cover to the base enclosure.

2. Remove the left-side rear corner cover **(2)**.

The left-side rear corner cover is included in the Hinge Cover Kit, spare part number 734294-001.

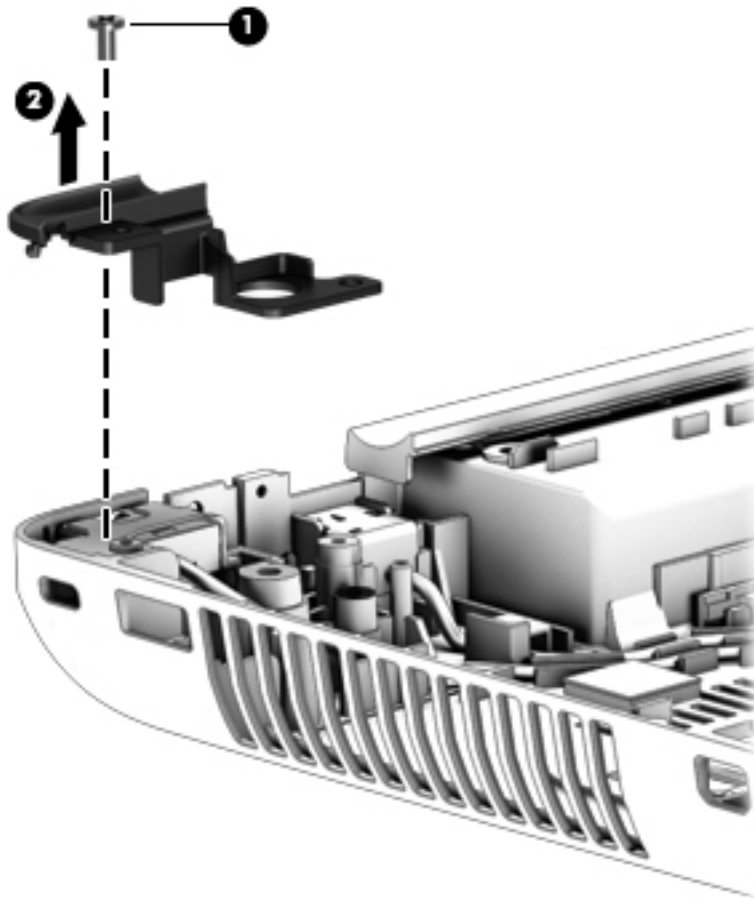

3. Remove the Phillips PM2.0x5.5 screw **(1)** that secures the security cable lock bracket to the base enclosure.
4. Remove the security cable lock bracket **(2)**.

The security cable lock bracket is included in the Bracket Kit, spare part number 734299-001.

5. Remove the RJ-45 (network) cable (3).

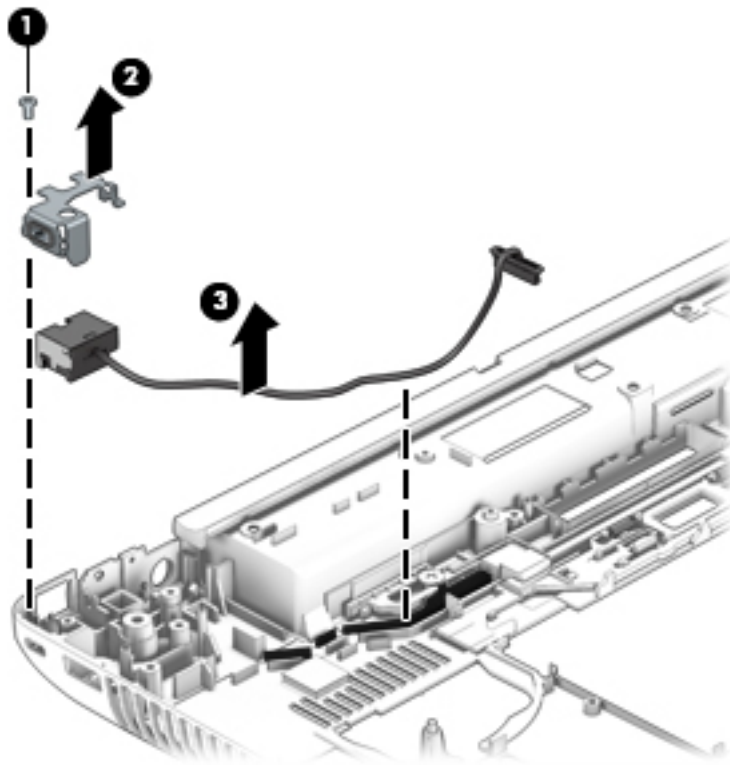

Reverse this procedure to install the RJ-45 (network) cable.

---

# 7 Computer Setup

## Windows 8 – Computer Setup (BIOS), MultiBoot, and System Diagnostics

### Using Computer Setup

Computer Setup, or Basic Input/Output System (BIOS), controls communication between all the input and output devices on the system (such as disk drives, display, keyboard, mouse, and printer). Computer Setup includes settings for the types of devices installed, the startup sequence of the computer, and the amount of system and extended memory.

---

 **NOTE:** Use extreme care when making changes in Computer Setup. Errors can prevent the computer from operating properly.

---

### Starting Computer Setup

---

 **NOTE:** An external keyboard or mouse connected to a USB port can be used with Computer Setup only if USB legacy support is enabled.

---

To start Computer Setup, follow these steps:

1. Turn on or restart the computer, and then press **esc** while the “press the ESC key for Startup Menu” message is displayed at the bottom of the screen.
2. press **f10** to enter Computer Setup.



## Navigating and selecting in Computer Setup

To navigate and select in Computer Setup, follow these steps:

1. Turn on or restart the computer, and then press **esc** while the “press the ESC key for Startup Menu” message is displayed at the bottom of the screen.



**NOTE:** You can use either a pointing device (TouchPad, pointing stick, or USB mouse) or the keyboard to navigate and make selections in Computer Setup.

2. press **f10** to enter Computer Setup.
  - To select a menu or a menu item, use the tab key and the keyboard arrow keys and then press enter, or use a pointing device to click the item.
  - To scroll up and down, click the up arrow or the down arrow in the upper-right corner of the screen, or use the up arrow key or the down arrow key on the keyboard.
  - To close open dialog boxes and return to the main Computer Setup screen, press **esc**, and then follow the on-screen instructions.

To exit Computer Setup menus, choose one of the following methods:

- To exit Computer Setup menus without saving your changes:

Click the **Exit** icon in the lower-right corner of the screen, and then follow the on-screen instructions.

– or –

Use the tab key and the arrow keys to select **File > Ignore Changes and Exit**, and then press **enter**.
- To save your changes and exit Computer Setup menus:

Click the **Save** icon in the lower-right corner of the screen, and then follow the on-screen instructions.

– or –

Use the tab key and the arrow keys to select **File > Save Changes and Exit**, and then press **enter**.

Your changes go into effect when the computer restarts.

## Restoring default settings in Computer Setup

 **NOTE:** Restoring default will not change the hard drive mode.

---

To return all settings in Computer Setup to the values that were set at the factory, follow these steps:

1. Turn on or restart the computer, and then press **esc** while the “press the ESC key for Startup Menu” message is displayed at the bottom of the screen.
2. press **f10** to enter Computer Setup.
3. Use a pointing device or the arrow keys to select **File > Restore Defaults**.
4. Follow the on-screen instructions.
5. To save your changes and exit, click the **Save** icon in the lower-right corner of the screen, and then follow the on-screen instructions.

– or –

Use the arrow keys to select **File > Save Changes and Exit**, and then press **enter**.

Your changes go into effect when the computer restarts.

 **NOTE:** Your password settings and security settings are not changed when you restore the default settings.

---

## Updating the BIOS

Updated versions of the BIOS may be available on the HP website.

Most BIOS updates on the HP website are packaged in compressed files called *SoftPaqs*.

Some download packages contain a file named *Readme.txt*, which contains information regarding installing and troubleshooting the file.

### Determining the BIOS version

To determine whether available BIOS updates contain later BIOS versions than those currently installed on the computer, you need to know the version of the system BIOS currently installed.

BIOS version information (also known as *ROM date* and *System BIOS*) can be displayed by pressing **fn +esc** (if you are already in Windows) or by using Computer Setup.

1. Start Computer Setup.
2. Use a pointing device or the arrow keys to select **File > System Information**.
3. To exit Computer Setup without saving your changes, click the **Exit** icon in the lower-right corner of the screen, and then follow the on-screen instructions.

– or –

Use the tab key and the arrow keys to select **File > Ignore Changes and Exit**, and then press **enter**.

## Downloading a BIOS update

 **CAUTION:** To reduce the risk of damage to the computer or an unsuccessful installation, download and install a BIOS update only when the computer is connected to reliable external power using the AC adapter. Do not download or install a BIOS update while the computer is running on battery power, docked in an optional docking device, or connected to an optional power source. During the download and installation, follow these instructions:

Do not disconnect power on the computer by unplugging the power cord from the AC outlet.

Do not shut down the computer or initiate Sleep.

Do not insert, remove, connect, or disconnect any device, cable, or cord.

1. From the Start screen, select the HP Support Assistant app.
2. Select **Updates and tune-ups**, and then select **Check for HP updates now**.
3. At the download area, follow these steps:
  - a. Identify the most recent BIOS update and compare it to the BIOS version currently installed on your computer. Make a note of the date, name, or other identifier. You may need this information to locate the update later, after it has been downloaded to your hard drive.
  - b. Follow the on-screen instructions to download your selection to the hard drive. If the update is more recent than your BIOS, make a note of the path to the location on your hard drive where the BIOS update is downloaded. You will need to access this path when you are ready to install the update.

 **NOTE:** If you connect your computer to a network, consult the network administrator before installing any software updates, especially system BIOS updates.

BIOS installation procedures vary. Follow any instructions that are displayed on the screen after the download is complete. If no instructions are displayed, follow these steps:

1. From the Start screen, type *e*, and then click **File Explorer**.
2. Click your hard drive designation. The hard drive designation is typically Local Disk (C:).
3. Using the hard drive path you recorded earlier, open the folder on your hard drive that contains the update.
4. Double-click the file that has an .exe extension (for example, *filename.exe*).  
The BIOS installation begins.
5. Complete the installation by following the on-screen instructions.

 **NOTE:** After a message on the screen reports a successful installation, you can delete the downloaded file from your hard drive.

# Using MultiBoot

## About the boot device order

As the computer starts, the system attempts to boot from enabled devices. The MultiBoot utility, which is enabled at the factory, controls the order in which the system selects a boot device. Boot devices can include optical drives, diskette drives, a network interface card (NIC), hard drives, and USB devices. Boot devices contain bootable media or files that the computer needs to start and operate properly.



**NOTE:** Some boot devices must be enabled in Computer Setup before they can be included in the boot order.

You can change the order in which the computer searches for a boot device by changing the boot order in Computer Setup. You can also press `esc` while the “press the ESC key for Startup Menu” message is displayed at the bottom of the screen, and then press `f9`. Pressing `f9` displays a menu that shows the current boot devices and allows you to select a boot device. Or, you can use MultiBoot Express to set the computer to prompt you for a boot location each time the computer turns on or restarts.

## Choosing MultiBoot preferences

You can use MultiBoot in the following ways:

- To set a new boot order that the computer uses each time it is turned on, by changing the boot order in Computer Setup.
- To dynamically choose the boot device, by pressing `esc` while the “press the ESC key for Startup Menu” message is displayed at the bottom of the screen, and then pressing `f9` to enter the Boot Device Options menu.
- To use MultiBoot Express to set variable boot orders. This feature prompts you for a boot device each time the computer is turned on or restarted.

## Setting a new boot order in Computer Setup

To start Computer Setup and set a boot device order that the computer uses each time it is turned on or restarted, follow these steps:

1. Turn on or restart the computer, and then press `esc` while the “press the ESC key for Startup Menu” message is displayed at the bottom of the screen.
2. press `f10` to enter Computer Setup.
3. Use a pointing device or the arrow keys to select the **Legacy Boot Order** list, and then press `enter`.
4. To move the device up in the boot order, use a pointing device to click the up arrow, or press the `+` key.

– or –

To move the device down in the boot order, use a pointing device to click the down arrow, or press the **-** key.

5. To save your changes and exit Computer Setup, click the **Save** icon in the lower-left corner of the screen, and then follow the on-screen instructions.

– or –

Use the arrow keys to select **File > Save Changes and Exit**, and then press [enter](#).

## Dynamically choosing a boot device using the f9 prompt

To dynamically choose a boot device for the current startup sequence, follow these steps:

1. Open the Select Boot Device menu by turning on or restarting the computer, and then pressing [esc](#) while the “press the ESC key for Startup Menu” message is displayed at the bottom of the screen.
2. press [f9](#).
3. Use a pointing device or the arrow keys to select a boot device, then press [enter](#).

## Setting a MultiBoot Express prompt

To start Computer Setup and set the computer to display the MultiBoot startup location menu each time the computer is started or restarted, follow these steps:

1. Turn on or restart the computer, and then press [esc](#) while the “press the ESC key for Startup Menu” message is displayed at the bottom of the screen.
2. press [f10](#) to enter Computer Setup.
3. Use a pointing device or the arrow keys to select **System Configuration > Boot Options**, and then press [enter](#).
4. In the **MultiBoot Express Popup Delay (Sec)** field, enter the length of time in seconds that you want the computer to display the startup location menu before it defaults to the current MultiBoot setting. (When 0 is selected, the Express Boot startup location menu is not displayed.)
5. To save your changes and exit Computer Setup, click the **Save** icon in the lower-left corner of the screen, and then follow the on-screen instructions.

– or –

Use the arrow keys to select **File > Save Changes and Exit**, and then press [enter](#).

Your changes go into effect when the computer restarts.

## Entering MultiBoot Express preferences

When the Express Boot menu is displayed during startup, you have the following choices:

- To specify a boot device from the Express Boot menu, select your preference within the allotted time, and then press **enter**.
- To prevent the computer from defaulting to the current MultiBoot setting, press any key before the allotted time expires. The computer will not start until you select a boot device and press **enter**.
- To allow the computer to start according to the current MultiBoot settings, wait for the allotted time to expire.

## Using System Diagnostics

System Diagnostics allows you to run diagnostic tests to determine if the computer hardware is functioning properly. The following diagnostic tests may be available in System Diagnostics:

- **System Tune-Up**—This group of additional tests checks your computer to make sure that the main components are functioning correctly. System Tune-Up runs longer and more comprehensive tests on memory modules, hard drive SMART attributes, the hard drive surface, the battery (and battery calibration), video memory, and the WLAN module status.
- **Start-up test**—This test analyzes the main computer components that are required to start the computer.
- **Run-in test**—This test repeats the start-up test and checks for intermittent problems that the start-up test does not detect.
- **Hard disk test**—This test analyzes the physical condition of the hard drive, and then checks all data in every sector of the hard drive. If the test detects a damaged sector, it attempts to move the data to a good sector.
- **Memory test**—This test analyzes the physical condition of the memory modules. If it reports an error, replace the memory modules immediately.
- **Battery test**—This test analyzes the condition of the battery and calibrates the battery if necessary. If the battery fails the test, contact HP support to report the issue and purchase a replacement battery.
- **BIOS Management**—You can update or rollback the version of the BIOS on the system. Do not shut down or remove external power during the process. You will be given a confirmation screen before your BIOS is modified. Select BIOS update, BIOS Rollback, or Back to main menu.

You can view system information and error logs or select languages in the System Diagnostics window.

To start System Diagnostics:

1. Turn on or restart the computer. While the “press the ESC key for Startup Menu” message is displayed in the lower-left corner of the screen, press **esc**. When the Startup Menu is displayed, press **f2**.
2. Click the diagnostic test you want to run, and then follow the on-screen instructions.

---

 **NOTE:** If you need to stop a diagnostics test while it is running, press `esc`.

---

# Windows 7 — Computer Setup (BIOS), MultiBoot, and HP PC Hardware Diagnostics (UEFI)

## Using Computer Setup

Computer Setup, or Basic Input/Output System (BIOS), controls communication between all the input and output devices on the system (such as disk drives, display, keyboard, mouse, and printer). Computer Setup includes settings for the types of devices installed, the startup sequence of the computer, and the amount of system and extended memory.

---

 **NOTE:** Use extreme care when making changes in Computer Setup. Errors can prevent the computer from operating properly.

---

## Starting Computer Setup

---

 **NOTE:** An external keyboard or mouse connected to a USB port can be used with Computer Setup only if USB legacy support is enabled.

---

To start Computer Setup, follow these steps:

1. Turn on or restart the computer, and then press `esc` while the “press the ESC key for Startup Menu” message is displayed at the bottom of the screen.
2. press `f10` to enter Computer Setup.

## Navigating and selecting in Computer Setup

To navigate and select in Computer Setup, follow these steps:

1. Turn on or restart the computer, and then press `esc` while the “press the ESC key for Startup Menu” message is displayed at the bottom of the screen.

---

 **NOTE:** You can use either a pointing device (TouchPad, pointing stick, or USB mouse) or the keyboard to navigate and make selections in Computer Setup.

---

2. press `f10` to enter Computer Setup.
  - To select a menu or a menu item, use the `tab` key and the keyboard arrow keys and then press `enter`, or use a pointing device to click the item.
  - To scroll up and down, click the up arrow or the down arrow in the upper-right corner of the screen, or use the up arrow key or the down arrow key on the keyboard.
  - To close open dialog boxes and return to the main Computer Setup screen, press `esc`, and then follow the on-screen instructions.

To exit Computer Setup menus, choose one of the following methods:

- To exit Computer Setup menus without saving your changes:

Click the **Exit** icon in the lower-right corner of the screen, and then follow the on-screen instructions.

– or –

Use the **tab** key and the arrow keys to select **File > Ignore Changes and Exit**, and then press **enter**.

- To save your changes and exit Computer Setup menus:

Click the **Save** icon in the lower-right corner of the screen, and then follow the on-screen instructions.

– or –

Use the **tab** key and the arrow keys to select **File > Save Changes and Exit**, and then press **enter**.

Your changes go into effect when the computer restarts.

## Restoring default settings in Computer Setup

---

 **NOTE:** Restoring defaults will not change the hard drive mode.

---

To return all settings in Computer Setup to the values that were set at the factory, follow these steps:

1. Turn on or restart the computer, and then press **esc** while the “press the ESC key for Startup Menu” message is displayed at the bottom of the screen.
2. press **f10** to enter Computer Setup.
3. Use a pointing device or the arrow keys to select **File > Restore Defaults**.
4. Follow the on-screen instructions.
5. To save your changes and exit, click the **Save** icon in the lower-right corner of the screen, and then follow the on-screen instructions.

– or –

Use the arrow keys to select **File > Save Changes and Exit**, and then press **enter**.

Your changes go into effect when the computer restarts.

---

 **NOTE:** Your password settings and security settings are not changed when you restore the default settings.

---



## Updating the BIOS

Updated versions of the BIOS may be available on the HP website.

Most BIOS updates on the HP website are packaged in compressed files called *SoftPaqs*.

Some download packages contain a file named *Readme.txt*, which contains information regarding installing and troubleshooting the file.

### Determining the BIOS version

To determine whether available BIOS updates contain later BIOS versions than those currently installed on the computer, you need to know the version of the system BIOS currently installed.

BIOS version information (also known as *ROM date* and *System BIOS*) can be displayed by pressing **fn** + **esc** (if you are already in Windows) or by using Computer Setup.

1. Start Computer Setup.
2. Use a pointing device or the arrow keys to select **File > System Information**.
3. To exit Computer Setup without saving your changes, click the **Exit** icon in the lower-right corner of the screen, and then follow the on-screen instructions.

– or –

Use the **tab** key and the arrow keys to select **File > Ignore Changes and Exit**, and then press **enter**.

### Downloading a BIOS update

 **CAUTION:** CAUTION: To reduce the risk of damage to the computer or an unsuccessful installation, download and install a BIOS update only when the computer is connected to reliable external power using the AC adapter. Do not download or install a BIOS update while the computer is running on battery power, docked in an optional docking device, or connected to an optional power source. During the download and installation, follow these instructions:

Do not disconnect power on the computer by unplugging the power cord from the AC outlet.

Do not shut down the computer or initiate Sleep.

Do not insert, remove, connect, or disconnect any device, cable, or cord.

1. Access Help and Support by selecting **Start > Help and Support**.
2. Select **Updates and tune-ups**, and then select **Check for HP updates now**.
3. At the download area, follow these steps:
  - a. Identify the most recent BIOS update and compare it to the BIOS version currently installed on your computer. Make a note of the date, name, or other identifier. You may need this information to locate the update later, after it has been downloaded to your hard drive.
  - b. Follow the on-screen instructions to download your selection to the hard drive. If the update is more recent than your BIOS, make a note of the path to the location on your hard drive

where the BIOS update is downloaded. You will need to access this path when you are ready to install the update.

---

 **NOTE:** If you connect your computer to a network, consult the network administrator before installing any software updates, especially system BIOS updates.

---

BIOS installation procedures vary. Follow any instructions that are displayed on the screen after the download is complete. If no instructions are displayed, follow these steps:

1. Select **Start > Computer**.
2. Click your hard drive designation. The hard drive designation is typically Local Disk (C:).
3. Using the hard drive path you recorded earlier, open the folder on your hard drive that contains the update.
4. Double-click the file that has an .exe extension (for example, *filename.exe*). The BIOS installation begins.
5. Complete the installation by following the on-screen instructions.

---

 **NOTE:** After a message on the screen reports a successful installation, you can delete the downloaded file from your hard drive.

---

## Using MultiBoot

### About the boot device order

As the computer starts, the system attempts to boot from enabled devices. The MultiBoot utility, which is enabled at the factory, controls the order in which the system selects a boot device. Boot devices can include optical drives, diskette drives, a network interface card (NIC), hard drives, and USB devices. Boot devices contain bootable media or files that the computer needs to start and operate properly.

---

 **NOTE:** Some boot devices must be enabled in Computer Setup before they can be included in the boot order.

---

You can change the order in which the computer searches for a boot device by changing the boot order in Computer Setup. You can also press **esc** while the “press the ESC key for Startup Menu” message is displayed at the bottom of the screen, and then press **f9**. Pressing **f9** displays a menu that shows the current boot devices and allows you to select a boot device. Or, you can use MultiBoot Express to set the computer to prompt you for a boot location each time the computer turns on or restarts.

## Choosing MultiBoot preferences

You can use MultiBoot in the following ways:

- To set a new boot order that the computer uses each time it is turned on, by changing the boot order in Computer Setup.
- To dynamically choose the boot device, by pressing `esc` while the “press the ESC key for Startup Menu” message is displayed at the bottom of the screen, and then pressing `f9` to enter the Boot Device Options menu.
- To use MultiBoot Express to set variable boot orders. This feature prompts you for a boot device each time the computer is turned on or restarted.

### Setting a new boot order in Computer Setup

To start Computer Setup and set a boot device order that the computer uses each time it is turned on or restarted, follow these steps:

1. Turn on or restart the computer, and then press `esc` while the “press the ESC key for Startup Menu” message is displayed at the bottom of the screen.
2. press `f10` to enter Computer Setup.
3. Use a pointing device or the arrow keys to select the **Legacy Boot Order** list, and then press `enter`.
4. To move the device up in the boot order, use a pointing device to click the up arrow, or press the `+` key.  
– or –  
To move the device down in the boot order, use a pointing device to click the down arrow, or press the `-` key.
5. To save your changes and exit Computer Setup, click the **Save** icon in the lower-left corner of the screen, and then follow the on-screen instructions.  
– or –  
Use the arrow keys to select **File > Save Changes and Exit**, and then press `enter`.

### Dynamically choosing a boot device using the `f9` prompt

To dynamically choose a boot device for the current startup sequence, follow these steps:

1. Open the Select Boot Device menu by turning on or restarting the computer, and then pressing `esc` while the “press the ESC key for Startup Menu” message is displayed at the bottom of the screen.
2. press `f9`.
3. Use a pointing device or the arrow keys to select a boot device, then press `enter`.

## Setting a MultiBoot Express prompt

To start Computer Setup and set the computer to display the MultiBoot startup location menu each time the computer is started or restarted, follow these steps:

1. Turn on or restart the computer, and then press **esc** while the “press the ESC key for Startup Menu” message is displayed at the bottom of the screen.
2. press **f10** to enter Computer Setup.
3. Use a pointing device or the arrow keys to select **System Configuration > Boot Options**, and then press **enter**.
4. In the **MultiBoot Express Popup Delay (Sec)** field, enter the length of time in seconds that you want the computer to display the startup location menu before it defaults to the current MultiBoot setting. (When 0 is selected, the Express Boot startup location menu is not displayed.)
5. To save your changes and exit Computer Setup, click the **Save** icon in the lower-left corner of the screen, and then follow the on-screen instructions.

– or –

Use the arrow keys to select **File > Save Changes and Exit**, and then press **enter**.

## Entering MultiBoot Express preferences

When the Express Boot menu is displayed during startup, you have the following choices:

- To specify a boot device from the Express Boot menu, select your preference within the allotted time, and then press **enter**.
- To prevent the computer from defaulting to the current MultiBoot setting, press any key before the allotted time expires. The computer will not start until you select a boot device and press **enter**.
- To allow the computer to start according to the current MultiBoot settings, wait for the allotted time to expire.

## Using HP PC Hardware Diagnostics (UEFI) (select models only)

HP PC Hardware Diagnostics is a Unified Extensible Firmware Interface (UEFI) that allows you to run diagnostic tests to determine if the computer hardware is functioning properly. The tool runs outside of the operating system to isolate hardware failures from issues that may be caused by the operating system or other software components.

To start HP PC Hardware Diagnostics UEFI:

1. Turn on or restart the computer, quickly press **esc**, and then press **f2**.

After pressing **f2**, the BIOS searches three places for the HP PC Hardware Diagnostics (UEFI) tools in the following order:

- a. Connected USB drive

 **NOTE:** To download the HP PC Hardware Diagnostics (UEFI) tool to a USB drive, see [Downloading HP PC Hardware Diagnostics \(UEFI\) to a USB device on page 125](#).

- b. Hard drive

- c. BIOS

2. Click the type of diagnostic test you want to run, and then follow the on-screen instructions.

 **NOTE:** If you need to stop a diagnostic test while it is running, press **esc**.

## Downloading HP PC Hardware Diagnostics (UEFI) to a USB device

 **NOTE:** The HP PC Hardware Diagnostics (UEFI) download instructions are provided in English only.

1. Go to <http://www.hp.com>.
2. Click **Support & Drivers**, and then click the **Drivers & Software** tab.
3. Enter the product name in the text box, and then click **Search**.
4. Select your computer model, and then select your operating system.
5. In the Diagnostic section, click **HP UEFI Support Environment**.

– or –

Click **Download**, and then select **Run**.

# 8 Specifications

## Computer specifications

	Metric	U.S.
<b>Dimensions</b>		
Width	<b>38.2 cm</b>	15.0 in
Depth	<b>25.7 cm</b>	10.1 in
Height (front to rear, DreamColor display assembly)	<b>3.4 to 3.9 cm</b>	1.3 to 1.5 in
Height (front to rear, LED display assembly)	<b>3.1 to 3.6 cm</b>	1.2 to 1.4 in
Weight (computer equipped with Intel Dual Core processor, 320-GB hard drive, optical drive, one memory module, WLAN module, fingerprint reader, modem module, and 8-cell battery)	<b>2.93 kg</b>	6.46 lb
Weight (computer equipped with Intel Dual Core processor one memory module, 128-GB solid-state drive, WLAN module, fingerprint reader, and 8-cell battery)	<b>2.82 kg</b>	6.22 lb
<b>Input power</b>		
Operating voltage and current	19.5 V dc @ 6.15 A - 120 W, Slim Smart AC Adapter (select models only)	
	19.5 V dc @ 7.69 A - 150 W, Slim Smart AC Adapter (select models only)	
	19.5 V dc @ 10.3A - 200 W, Slim Smart AC Adapter (select models only)	
<b>Temperature</b>		
Operating	<b>5°C to 35°C</b>	41°F to 95°F
Nonoperating	<b>-20°C to 60°C</b>	-4°F to 140°F
<b>Relative humidity</b> (non-condensing)		
Operating	10% to 90%	
Nonoperating	5% to 95%	
<b>Maximum altitude</b> (unpressurized)		

	<b>Metric</b>	<b>U.S.</b>
Operating	<b>-15 m to 3,048 m</b>	-50 ft to 10,000 ft
Nonoperating	<b>-15 m to 12,192 m</b>	-50 ft to 40,000 ft

**NOTE:** Applicable product safety standards specify thermal limits for plastic surfaces. The device operates well within this range of temperatures.

## Hard drive specifications

	<b>1-TB, 5400-rpm*</b>	<b>750-GB, 5400-rpm**</b>	<b>640-GB, 5400-rpm**</b>
<b>Dimensions</b>			
Height	9.5 mm	9.5 mm	9.5 mm
Length	100.4 mm	100.4 mm	100.4 mm
Width	69.9 mm	69.9 mm	69.9 mm
Weight	110 g	110 g	110 g
<b>Interface type</b>	SATA	SATA	SATA
<b>Transfer rate</b>			
Synchronous (maximum)	1.1 GB/sec	1.1 GB/sec	1.1 GB/sec
Security	ATA security	ATA security	ATA security
<b>Seek times</b> (typical read, including setting)			
Single track	1.5 ms	1.5 ms	1.5 ms
Average (read/write)	11/13 ms	11/13 ms	11/13 ms
Maximum	22 ms	22 ms	22 ms
<b>Logical blocks</b>	1,953,525,168	1,465,149,168	1,250,263,728
<b>Disk rotational speed</b>	5400 rpm		
<b>Operating temperature</b>	0°C to 60°C (32°F to 140°F)		
*1 TB = 1 trillion bytes when referring to hard drive storage capacity. Actual accessible capacity is less.			
**1 GB = 1 billion bytes when referring to hard drive storage capacity. Actual accessible capacity is less.			
<b>NOTE:</b> Certain restrictions and exclusions apply. Contact technical support for details.			

## Hard drive specifications *(continued)*

	500-GB, 5400-rpm**	320-GB, 5400-rpm**
<b>Dimensions</b>		
Height	9.5 mm	9.5 mm
Length	100.4 mm	100.4 mm
Width	69.9 mm	69.9 mm
Weight	110 g	110 g
<b>Interface type</b>	SATA	SATA
<b>Transfer rate</b>		
Synchronous (maximum)	1.1 GB/sec	1.1 GB/sec
Security	ATA security	ATA security
<b>Seek times</b> (typical read, including setting)		
1.5 ms	1.5 ms	1.5 ms
11/13 ms	11/13 ms	11/13 ms
22 ms	22 ms	22 ms
Single track	1.5 ms	1.5 ms
Average (read/write)	11/13 ms	11/13 ms
Maximum	22 ms	22 ms
<b>Logical blocks</b>	976,773,168	628,142,448
<b>Disk rotational speed</b>	5400 rpm	
<b>Operating temperature</b>	0°C to 60°C (32°F to 140°F)	
*1 TB = 1 trillion bytes when referring to hard drive storage capacity. Actual accessible capacity is less.		
**1 GB = 1 billion bytes when referring to hard drive storage capacity. Actual accessible capacity is less.		
<b>NOTE:</b> Certain restrictions and exclusions apply. Contact technical support for details.		



---

# 9 Backup and recovery

## Windows 8

To protect your information, use Windows backup and restore utilities to back up individual files and folders, back up your entire hard drive, create system repair media (select models only) by using the installed optical drive (select models only) or an optional external optical drive, or create system restore points. In case of system failure, you can use the backup files to restore the contents of your computer.

From the Start screen, type `restore`, click **Settings**, and then select from the list of displayed options.

 **NOTE:** For detailed instructions on various backup and restore options, perform a search for these topics in HP Support Assistant. To access HP Support Assistant from the Start screen, select the **HP Support Assistant** app.

In case of system instability, HP recommends that you print the recovery procedures and save them for later use.

 **NOTE:** Windows includes the User Account Control feature to improve the security of your computer. You may be prompted for your permission or password for tasks such as installing software, running utilities, or changing Windows settings. Refer to HP Support Assistant. To access HP Support Assistant from the Start screen, select the **HP Support Assistant** app.

## Backing up your information

Recovery after a system failure is as good as your most recent backup. You should create system repair media and your initial backup immediately after initial system setup. As you add new software and data files, you should continue to back up your system on a regular basis to maintain a reasonably current backup. The system repair media (select models only) are used to start up (boot) the computer and repair the operating system in case of system instability or failure. Your initial and subsequent backups allow you to restore your data and settings if a failure occurs.

On Start screen, type `backup`, click **Settings**, and then select **Save backup copies of your files with File History**.

You can back up your information to an optional external hard drive or a network drive.

Note the following when backing up:

- Store personal files in the Documents library, and back it up regularly.
- Back up templates that are stored in their associated programs.
- Save customized settings that appear in a window, toolbar, or menu bar by taking a screen shot of your settings. The screen shot can be a time-saver if you have to reset your preferences.

To create a backup using Backup and Restore:

---

 **NOTE:** Be sure that the computer is connected to AC power before you start the backup process.

 **NOTE:** The backup process may take over an hour, depending on file size and the speed of the computer.

---

1. From the Start screen, type `backup`, click **Settings**, and then select from the list of displayed options.
2. Follow the on-screen instructions to set up your backup, create a system image (select models only), or create system repair media (select models only).

## Performing a system recovery

In case of system failure or instability, the computer provides the following tools to recover your files:

- Windows recovery tools: You can use Windows Backup and Restore to recover information you have previously backed up. You can also use Windows Automatic Repair to fix problems that might prevent Windows from starting correctly.
- `f11` recovery tools: You can use the `f11` recovery tools to recover your original hard drive image. The image includes the Windows operating system and software programs installed at the factory.

---

 **NOTE:** If you are unable to boot (start up) your computer and you cannot use the system repair media you previously created (select models only), you must purchase Windows 8 operating system media to reboot the computer and repair the operating system. For additional information, see [Using Windows 8 operating system media \(purchased separately\) on page 132](#).

---

## Using the Windows recovery tools

To recover information you previously backed up:

- ▲ Access HP Support Assistant. To access HP Support Assistant from the Start screen, select the **HP Support Assistant** app.

To recover your information using Automatic Repair, follow these steps:

---

 **CAUTION:** Some Automatic Repair options will completely erase and reformat the hard drive. All files you have created and any software installed on the computer are permanently removed. When reformatting is complete, the recovery process restores the operating system, as well as the drivers, software, and utilities from the backup used for recovery.

---

1. If possible, back up all personal files.
2. If possible, check for the presence of the HP Recovery partition and the Windows partition. From the Start screen, type `e`, and then click **File Explorer**.

– or –

From the Start screen, type `c`, and then select **Computer**.

---

 **NOTE:** If the Windows partition and the HP Recovery partition are not listed, you must recover your operating system and programs using the Windows 8 operating system DVD and the Driver Recovery media (both purchased separately). For additional information, see [Using Windows 8 operating system media \(purchased separately\) on page 132](#).

---

3. If the Windows partition and the HP Recovery partition are listed, restart the computer. After Windows has loaded, press and hold the `shift` key while clicking **Restart**.
4. Select **Troubleshoot**, then select **Advanced Options**, and then select **Automatic Repair**.
5. Follow the on-screen instructions.

---

 **NOTE:** For additional information on recovering information using the Windows tools, perform a search for these topics in HP Support Assistant. To access HP Support Assistant from the Start screen, select the **HP Support Assistant** app.

---

## Using f11 recovery tools

 **CAUTION:** Using **f11** completely erases hard drive contents and reformats the hard drive. All files that you have created and any software that you have installed on the computer are permanently removed. The **f11** recovery tool reinstalls the operating system and HP programs and drivers that were installed at the factory. Software not installed at the factory must be reinstalled.

To recover the original hard drive image using **f11**:

1. If possible, back up all personal files.
2. If possible, check for the presence of the HP Recovery partition: From the Start screen, type **C**, and then select **Computer**.

 **NOTE:** If the HP Recovery partition is not listed, you must recover your operating system and programs using the Windows 8 operating system media and the Driver Recovery media (both purchased separately). For additional information, see [Using Windows 8 operating system media \(purchased separately\) on page 132](#).

3. If the HP Recovery partition is listed, restart the computer, and then press **esc** while the “Press the ESC key for Startup Menu” message is displayed at the bottom of the screen.
4. Press **f11** while the “Press <F11> for recovery” message is display on the screen.
5. Follow the on-screen instructions.

## Using Windows 8 operating system media (purchased separately)

To order a Windows 8 operating system DVD, go to <http://www.hp.com/support>, select your country or region, and follow the on-screen instructions. You can also order the DVD by calling support. For contact information, see the *Worldwide Telephone Numbers* booklet included with the computer.

 **CAUTION:** Using a Windows 8 operating system media completely erases hard drive contents and reformats the hard drive. All files that you have created and any software that you have installed on the computer are permanently removed. When reformatting is complete, the recovery process helps you restore the operating system, as well as drivers, software, and utilities.

To initiate recovery using a Windows 8 operating system DVD:

 **NOTE:** This process takes several minutes.

1. If possible, back up all personal files.
2. Restart the computer, and then insert the Windows 8 operating system DVD into the optical drive before the Windows operating system loads.
3. When prompted, press any keyboard key.
4. Follow the on-screen instructions.

After the repair is completed:

1. Eject the Windows 8 operating system media and then insert the *Driver Recovery* media.
2. Install the Hardware Enabling Drivers first, and then install Recommended Applications.

## Using Windows Refresh for quick and easy recovery

When your computer is not working properly and you need to regain system stability, the Windows Refresh option allows you to start fresh and keep what is important to you.

---

 **IMPORTANT:** Refresh removes any traditional applications that were not originally installed on the system at the factory.

 **NOTE:** During Refresh, a list of removed traditional applications will be saved so that you have a quick way to see what you might need to reinstall. See HP Support Assistant for instructions on reinstalling traditional applications. To access HP Support Assistant from the Start screen, select the **HP Support Assistant** app.

 **NOTE:** You may be prompted for your permission or password when using Refresh. See HP Support Assistant for more information. To access HP Support Assistant from the Start screen, select the **HP Support Assistant** app.

---

To start Refresh:

1. From the Start screen, point to the far-right upper or lower corner of the screen to display the charms.
2. Click **Settings**.
3. Click **Change PC settings** in the bottom-right corner of the screen, and then select **General** from the PC settings screen.
4. Scroll the right-side choices down to display **Refresh your PC without affecting your files**.
5. Under **Refresh your PC without affecting your files**, select **Get started**, and follow the onscreen instructions.

## Remove everything and reinstall Windows

Sometimes you want to perform detailed reformatting of your computer, or you want to remove personal information before you give away or recycle your computer. The process described in this section provides a speedy, simple way to return the computer to its original state. This option removes all personal data, apps, and settings from your computer, and reinstalls Windows.

---

 **IMPORTANT:** This option does not provide backups of your information. Before using this option, back up any personal information you wish to retain.

---

You can initiate this option by using the **f11** key or from the Start screen.

To use the **f11** key:

1. Press **f11** while the computer boots.  
– or –  
Press and hold **f11** as you press the power button.
2. Choose your language.
3. Choose your keyboard layout.

4. Select **Troubleshoot** from the boot options menu.
5. Select **Reset your PC**, and follow the on-screen instructions.

To use the Start screen:

1. From the Start screen, point to the far-right upper or lower corner of the screen to display the charms.
2. Click **Settings**.
3. Click **Change PC settings** in the bottom-right corner of the screen, and then select **General** from the PC settings screen.
4. Scroll the right-side choices down to display **Remove everything and reinstall Windows**.
5. Under **Remove everything and reinstall Windows**, select **Get started**, and follow the onscreen instructions.

## Using HP Software Setup

HP Software Setup can be used to reinstall drivers or select software that has been corrupted or deleted from the system.

1. From the Start screen, type `HP Software Setup`, and select **Apps**.
2. Open **HP Software Setup**.
3. Follow the on-screen directions to reinstall drivers or select software.

# Windows 7

Your computer includes HP and Windows tools to help you safeguard your information and retrieve it if you ever need to. These tools will help you return your computer to a proper working state, all with simple steps. This section provides information about the following processes:

- Creating recovery media and backups
- Restoring and recovering your system

## Creating recovery media and backups

Recovery after a system failure is only as good as your most recent backup.

1. After you successfully set up the computer, create HP Recovery media. This step creates a Windows 7 operating system DVD and a Driver Recovery DVD. The Windows DVD can be used to reinstall the original operating system in cases where the hard drive is corrupted or has been replaced. The Driver Recovery DVD installs specific drivers and applications. See [Creating recovery media with HP Recovery Disc Creator on page 136](#).
2. Use Windows Backup and Recovery tools to perform the following:
  - Back up individual files and folders
  - Back up your entire hard drive (select models only)
  - Create system repair discs (select models only) with the installed optical drive (select models only) or an optional external optical drive
  - Create system restore points

---

 **NOTE:** This guide describes an overview of backing up, restoring, and recovering options. For more details about the tools provided, see Help and Support. To access Help and Support, select **Start > Help and Support**.

 **NOTE:** HP recommends that you print the recovery procedures and save them for later use, in case of system instability.

---

In case of system failure, you can use the backup files to restore the contents of your computer. See [Backing up your information on page 136](#).

## Guidelines

- When creating recovery media or backing up to discs, use any of the following types of discs (purchased separately): DVD+R, DVD+R DL, DVD-R, DVD-R DL, or DVD±RW. The discs you use will depend on the type of optical drive you are using.
- Be sure that the computer is connected to AC power before you start the recovery media creation process or the backup process.

## Creating recovery media with HP Recovery Disc Creator

HP Recovery Disc Creator is a software program that offers an alternative way to create recovery media. After you successfully set up the computer, you can create recovery media using HP Recovery Disc Creator. This recovery media allows you to reinstall your original operating system as well as select drivers and applications if the hard drive becomes corrupted. HP Recovery Disc Creator can create two kinds of recovery DVDs:

- Windows 7 operating system DVD—Installs the operating system without additional drivers or applications.
- *Driver Recovery DVD*—Installs specific drivers and applications only, in the same way that the HP Software Setup utility installs drivers and applications.

### Creating recovery media



**NOTE:** The Windows 7 operating system DVD can be created only once. Thereafter, the option to create that media will not be available after you create a Windows DVD.

To create the Windows DVD:

1. Select **Start > All Programs > Productivity and Tools > HP Recovery Disc Creator**.
2. Select **Windows disk**.
3. From the drop-down menu, select the drive for burning the recovery media.
4. Click the **Create** button to start the burning process.

After the Windows 7 operating system DVD has been created, create the *Driver Recovery DVD*:

1. Select **Start > All Programs > Productivity and Tools > HP Recovery Disc Creator**.
2. Select **Driver disk**.
3. From the drop-down menu, select the drive for burning the recovery media.
4. Click the **Create** button to start the burning process.

## Backing up your information

You should create system repair media and your initial backup immediately after initial system setup. As you add new software and data files, you should continue to back up your system on a regular basis to maintain a reasonably current backup. You should also create Windows system repair media (select models only) which can be used to start up (boot) the computer and repair the operating system in case of system instability or failure. Your initial and subsequent backups allow you to restore your data and settings if a failure occurs.

You can back up your information to an optional external hard drive, a network drive, or discs.

Note the following when backing up:

- Store personal files in the Documents library, and back it up regularly.
- Back up templates that are stored in their associated directories.



- Save customized settings that appear in a window, toolbar, or menu bar by taking a screen shot of your settings. The screen shot can be a time-saver if you have to reset your preferences.
- When backing up to discs, number each disc after removing it from the drive.

---

 **NOTE:** For detailed instructions on various backup and restore options, perform a search for these topics in Help and Support. To access Help and Support, select **Start > Help and Support**.

 **NOTE:** Windows includes the User Account Control feature to improve the security of your computer. You may be prompted for your permission or password for tasks such as installing software, running utilities, or changing Windows settings. Refer to Help and Support. To access Help and Support, select **Start > Help and Support**.

---

To create a backup using Windows Backup and Restore:

---

 **NOTE:** The backup process may take over an hour, depending on file size and the speed of the computer.

---

1. Select **Start > All Programs > Maintenance > Backup and Restore**.
2. Follow the on-screen instructions to set up your backup, create a system image (select models only), or create system repair media (select models only).

## Performing a system recovery

In case of system failure or instability, the computer provides the following tools to recover your files:

- Windows recovery tools: You can use Windows Backup and Restore to recover information you have previously backed up. You can also use Windows Startup Repair to fix problems that might prevent Windows from starting correctly.
- **f11** recovery tools (select models only): You can use the **f11** recovery tools to recover your original hard drive image. The image includes the Windows operating system and software programs installed at the factory.

---

 **NOTE:** If you are unable to boot (start up) your computer and you cannot use the system repair media you previously created (select models only), you must purchase Windows 7 operating system media to reboot the computer and repair the operating system. For additional information, see [Using Windows 7 operating system media on page 139](#).

---

## Using the Windows recovery tools

Using the Windows recovery tools, you can:

- Recover individual files
- Restore the computer to a previous system restore point
- Recover information using recovery tools

---

 **NOTE:** For detailed instructions on various recovery and restore options, perform a search for these topics in Help and Support. To access Help and Support, select **Start > Help and Support**.

 **NOTE:** Windows includes the User Account Control feature to improve the security of your computer. You may be prompted for your permission or password for tasks such as installing software, running utilities, or changing Windows settings. Refer to Help and Support. To access Help and Support, select **Start > Help and Support**.

---

To recover information you previously backed up:

1. Select **Start > All Programs > Maintenance > Backup and Restore**.
2. Follow the on-screen instructions to recover your system settings, your computer (select models only), or your files.

To recover your information using Startup Repair, follow these steps:

 **CAUTION:** Some Startup Repair options will completely erase and reformat the hard drive. All files you have created and any software installed on the computer are permanently removed. When reformatting is complete, the recovery process restores the operating system, as well as the drivers, software, and utilities from the backup used for recovery.

---

1. If possible, back up all personal files.
2. If possible, check for the presence of the Windows partition.

To check for the Windows partition, select **Start > Computer**.

 **NOTE:** If the Windows partition is not listed, you must recover your operating system and programs using the Windows 7 operating system DVD and the Driver Recovery media. For additional information, see [Using Windows 7 operating system media on page 139](#).

---

3. If the Windows partition is listed, restart the computer, and then press **f8** before the Windows operating system loads.
4. Select **Startup Repair**.
5. Follow the on-screen instructions.

 **NOTE:** For additional information on recovering information using the Windows tools, select **Start > Help and Support**.

---

## Using f11 recovery tools (select models only)

 **CAUTION:** Using f11 completely erases hard drive contents and reformats the hard drive. All files that you have created and any software that you have installed on the computer are permanently removed. The f11 recovery tool reinstalls the operating system and HP programs and drivers that were installed at the factory. Software not installed at the factory must be reinstalled.

To recover the original hard drive image using f11:

1. If possible, back up all personal files.
2. If possible, check for the presence of the HP Recovery partition: click **Start**, right-click **Computer**, click **Manage**, and then click **Disk Management**.

 **NOTE:** If the HP Recovery partition is not listed, you must recover your operating system and programs using the Windows 7 operating system media and the Driver Recovery media. For additional information, see [Using Windows 7 operating system media on page 139](#).

3. If the HP Recovery partition is listed, restart the computer, and then press **esc** while the “Press the ESC key for Startup Menu” message is displayed at the bottom of the screen.
4. Press **f11** while the “Press <F11> for recovery” message is displayed on the screen.
5. Follow the on-screen instructions.

## Using Windows 7 operating system media

If you cannot use the recovery media you previously created using the HP Recovery Disc Creator (select models only), you must purchase a Windows 7 operating system DVD to reboot the computer and repair the operating system.

To order a Windows 7 operating system DVD, go to the HP website. For U.S. support, go to <http://www.hp.com/support>. For worldwide support, go to [http://welcome.hp.com/country/us/en/wwcontact\\_us.html](http://welcome.hp.com/country/us/en/wwcontact_us.html). You can also order the DVD by calling support. For contact information, see the *Worldwide Telephone Numbers* booklet included with the computer.

 **CAUTION:** Using a Windows 7 operating system DVD completely erases hard drive contents and reformats the hard drive. All files that you have created and any software that you have installed on the computer are permanently removed. When reformatting is complete, the recovery process helps you restore the operating system, as well as drivers, software, and utilities.

To initiate recovery using a Windows 7 operating system DVD:

 **NOTE:** This process takes several minutes.

1. If possible, back up all personal files.
2. Restart the computer, and then insert the Windows 7 operating system DVD into the optical drive before the Windows operating system loads.
3. When prompted, press any keyboard key.
4. Follow the on-screen instructions.

5. Click **Next**.
6. Select **Repair your computer**.
7. Follow the on-screen instructions.

After the repair is completed:

1. Eject the Windows 7 operating system DVD and then insert the *Driver Recovery DVD*.
2. Install the Hardware Enabling Drivers first, and then install Recommended Applications.

---

# 10 Statement of Volatility

The purpose of this document is to provide general information regarding non-volatile memory in industry-standards based HP Business Notebook PC systems and provide general instructions for restoring nonvolatile memory that can contain personal data after the system has been powered off and the hard drive has been removed.

HP Business Notebook PC products that use Intel®-based or AMD®-based system boards contain volatile DDR memory. The amount of nonvolatile memory present in the system depends upon the system configuration. Intel-based and AMD-based system boards contain nonvolatile memory subcomponents as originally shipped from HP assuming that no subsequent modifications have been made to the system and assuming that no applications, features, or functionality have been added to or installed on the system.

Following system shutdown and removal of all power sources from an HP Business Notebook PC system, personal data can remain on volatile system memory (DIMMs) for a finite period of time and will also remain in nonvolatile memory. The steps below will remove personal data from the notebook PC, including the nonvolatile memory found in Intel-based and AMD-based system boards. Some of these steps are disclosed in the Maintenance & Service Guides available for HP PC products available on the product support pages at [www.hp.com](http://www.hp.com).

1. Follow steps (a) through (l) below to restore the nonvolatile memory that can contain personal data. Restoring or re-programming nonvolatile memory that does not store personal data is neither necessary nor recommended.
  - a. Enter BIOS (F10) Setup by powering on the system and pressing **F10** when prompted near the bottom of the display, or press the **ESC** key to display the start up menu, then press **F10** . If the system has a BIOS administrator password, enter the password at the prompt.
  - b. Select the **File** menu, then **Restore Defaults**.
  - c. Select the **System Configuration** menu, then **Restore Security Defaults**.
  - d. If an asset or ownership tag is set, select the **Security** menu and scroll down to the **Utilities** menu. Select **System IDs**, and then select the tag that has been set. Press the spacebar once to clear the tag, then press **Enter** to return to the prior menu.
  - e. If a DriveLock password is set, select the **Security** menu, select **Hard Drive Tools**, scroll down to **DriveLock**, then select **DriveLock password**. Select the desired hard drive. Click **Disable protection**, enter the existing master DriveLock password, then press **Enter** to confirm and return to the prior menu. Repeat this procedure if more than one hard drive has a DriveLock password.

- f. If an Automatic DriveLock password is set, select the **Security** menu, select **Hard Drive Tools**, scroll down to **Automatic DriveLock**, then select the desired hard drive and disable protection. Repeat this procedure if more than one hard drive has an Automatic DriveLock password.
- g. Select the **File** menu, then **Reset BIOS Security** to factory default. Click **yes** at the warning message.
- h. Select the **File** menu, then **Save Changes and Exit**.
- i. Reboot the system. If the system has a Trusted Platform Module (TPM) and/or fingerprint sensor, one or two prompts will appear. One to clear the TPM and the other to Reset Fingerprint Sensor; press **F1** to accept or **F2** to reject.

If the HP notebook model number includes Intel® Centrino with VPro™, reboot the PC and enter BIOS Setup by pressing **F10** when prompted. Select **System Configuration**, then **AMT Options**. Then select **Un-configure AMT on next boot**. Select **Save** then **Yes**. Select the **File** menu, and then select **Save Changes and Exit**. Reboot the system and confirm that you want to un-configure AMT.

- j. If the optional Intel® Anti-Theft Technology (AT) was activated, contact the provider to deactivate it.
- k. If the optional Absolute® Software Computrace® management and tracking service was activated on the notebook PC, contact the provider to deactivate it.
- l. Remove all power and system batteries for at least 24 hours.

## 2. Remove and retain the storage drive or clear the contents of the drive.

### a. Hard Disk Drive (HDD)

Clear the HDD contents by using the HP Disk Sanitizer® utility or a third party application that, ideally, is U.S. Department of Defense (DOD) 5220.22-M approved.

To run HP Disk Sanitizer, enter BIOS Setup by powering on the system and pressing **F10** when prompted near the bottom of the display, or press **ESC** to display the start up menu, then press **F10**. Select the **Security** menu and scroll down to the **Utilities** menu. Select **Disk Sanitizer** and select the desired drive. For a higher level of protection, select **Optimum**.

---

 **NOTE:** This process will take a long time, and the amount of time varies based on the hard drive capacity.

---

### b. Solid State Drive (SSD)

Clear the SSD contents by using the BIOS Setup Secure Erase command option, or by using a third party utility designed to erase data from an SSD. To run Secure Erase, enter BIOS Setup by powering on the system and pressing **F10** when prompted near the bottom of the display. Select the **Security** menu and scroll down to the **Utilities** menu. Select **Secure Erase** and select the desired hard drive.

# Non-volatile memory usage

Non Volatile Memory Type	Amount (Size)	Does this memory store customer data?	Does this memory retain data when power is removed?	What is the purpose of this memory?	How is data input into this memory?	How is this memory write protected?
HP Sure Start flash	2 MB	No	Yes	Only in platforms that support Sure Start to provide protected backup of critical System BIOS code, EC firmware, and critical PC configuration data.	Data cannot be written to this device via the host processor. The content is managed solely by the HP Sure Start Embedded Controller.	Protected by the HP Sure Start Embedded Controller.
Real Time Clock (RTC) battery backed-up CMOS configuration memory (CMOS)	256 Bytes	No	Yes	Stores system date and time and limited keyboard controller data.	Using the F10 Setup utility or changing the Microsoft® Windows® date & time.	This memory is not write-protected. HP recommends password protecting the F10 Setup utility.
Controller (NIC) EEPROM	64 Kbytes (not customer accessible)	No	Yes	Store NIC configuration and NIC firmware.	Using a utility from the NIC vendor that can be run from DOS.	A utility is required to write data to this memory and is available from NIC vendor. Writing data to this ROM in an inappropriate manner will render the NIC non-functional.
Keyboard ROM	64 Kbytes (not customer accessible)	No	Yes	Stores firmware code (keyboard, mouse, & battery management).	Programmed at the factory. Code is updated when the system BIOS is updated.	A utility is required for writing data to this memory and is available on the HP website. Writing data to this ROM in an inappropriate manner can render the PC non-functional.
DIMM Serial Presence Detect (SPD) configuration data	256 Bytes per memory module, 128 Bytes programmable (not customer accessible)	No	Yes	Stores memory module information.	Programmed by the memory vendor.	Data cannot be written to this memory when the module is installed in a PC. The specific write protection method varies by memory vendor.

<b>Non Volatile Memory Type</b>	<b>Amount (Size)</b>	<b>Does this memory store customer data?</b>	<b>Does this memory retain data when power is removed?</b>	<b>What is the purpose of this memory?</b>	<b>How is data input into this memory?</b>	<b>How is this memory write protected?</b>
System BIOS	4 to 5 MBytes	Yes	Yes	Store system BIOS code and PC configuration data.	System BIOS code is programmed at the factory. Code is updated when the system BIOS is updated. Configuration data and settings are input using the F10 setup utility or a custom utility.	A utility is required for writing data to this memory and is available on the HP website. Writing data to this ROM in an inappropriate manner can render the PC non-functional.
Intel Management Engine Firmware (present only in models ending in a 'p' or 'w' or with Intel Centrino Pro technology)	1.5 or 5MByte	Yes	Yes	Stores Management Engine Code, Settings, Provisioning Data and iAMT third party data store.	Management Engine Code is programmed at the factory. Code is updated via Intel secure firmware update utility. Unique Provisioning Data can be entered at the factory or by an administrator using the Management Engine (MEBx) setup utility. The third party data store contents can be populated by a remote management console or local applications registered by an administrator to have access to the space.	The Intel chipset is configured to enforce HW protection to block all direct read/write access to this area. An Intel utility is required for updating the firmware. Only firmware updates digitally signed by Intel can be applied using this utility.
Bluetooth flash	2Mbit	No	Yes	Stores Bluetooth configuration and firmware.	Programmed at the factory. Tools for writing data to this memory are not publicly available but can be obtained from the silicon vendor.	A utility is required for writing data to this memory and is made available through newer versions of the driver if the flash requires an upgrade.
802.11 WLAN EEPROM	4kb to 8kb	No	Yes	Stores configuration and calibration data.	Programmed at the factory. Tools for writing data to this memory are not made public.	A utility is required for writing data to this memory and is typically not made available to the public unless a firmware upgrade is necessary to address a unique issue.
Web Camera	64K bit	No	Yes	Store Web Cam configuration and firmware.	Using a utility from the device manufacturer that can be run from Windows.	A utility is required for writing data to this memory and is typically not made available to the public unless a firmware upgrade is necessary to address a unique issue.
Fingerprint Reader	512kByte Flash	Yes	Yes	Stores fingerprint templates.	By enrolling in HP ProtectTools Security Manager.	Only a digitally signed application can make the call to write to the flash.



# Questions and answers

**1. How can the BIOS settings be restored (returned to factory settings)?**

- a. Turn on or restart the computer and press **F10** when prompted near the bottom of the display.
- b. Select **File**, then select **Restore defaults**.
- c. Follow the on-screen instructions.
- d. Select **File**, save changes and exit, then press **Enter**.

**2. What kind of configuration data is stored on the DIMM Serial Presence Detect (SPD) memory module? How would this data be written?**

The DIMM SPD memory contains information about the memory module such as size, serial number, data width, speed/timing, voltage and thermal information. This information is written by the module manufacturer and stored on an EEPROM. This EEPROM cannot be written to when the memory module is installed in a PC. Third party tools do exist that can write to the EEPROM when the memory module is not installed in a PC. There are various third party tools available to read SPD memory.

**3. Does the “Firmware Hub for System BIOS” contain the BIOS program? Is this chip writable, and if so how?**

The Firmware Hub does contain the BIOS program and is writable. A utility is required to perform the write function.

**4. In some PC systems, the Firmware Hub for System BIOS is a flash memory chip so that updates can be written by the customer. Is this true for these BIOS chips?**

Yes, they are flash memory chips.

**5. What is meant by “Restore the nonvolatile memory found in Intel-based system boards”?**

This relates to clearing the Real Time Clock (RTC) CMOS memory that contains PC configuration data.

**6. Does resetting the CMOS configuration memory return the PC back to factory defaults?**

The process of resetting the CMOS will return certain system settings to factory default but will not reset many of the system data and configuration defaults to their factory settings. To return these system data and configuration defaults to factory settings, refer to question and answer 1 and follow the instructions for returning the BIOS settings to factory defaults.

# 11 Power cord set requirements

The wide-range input feature of the computer permits it to operate from any line voltage from 100 to 120 volts AC, or from 220 to 240 volts AC.

The 3-conductor power cord set included with the computer meets the requirements for use in the country or region where the equipment is purchased.

Power cord sets for use in other countries and regions must meet the requirements of the country or region where the computer is used.

## Requirements for all countries

The following requirements are applicable to all countries and regions:

- The length of the power cord set must be at least 1.0 m (3.3 ft) and no more than 2.0 m (6.5 ft).
  - All power cord sets must be approved by an acceptable accredited agency responsible for evaluation in the country or region where the power cord set will be used.
  - The power cord sets must have a minimum current capacity of 10 amps and a nominal voltage rating of 125 or 250 V AC, as required by the power system of each country or region.
  - The appliance coupler must meet the mechanical configuration of an EN 60 320/IEC 320 Standard Sheet C13 connector for mating with the appliance inlet on the back of the computer.
- Requirements for all countries 113

## Requirements for specific countries and regions

Country/region	Accredited agency	Applicable note number
Australia	EANSW	1
Austria	OVE	1
Belgium	CEBC	1
Canada	CSA	2
Denmark	DEMKO	1
Finland	FIMKO	1

Country/region	Accredited agency	Applicable note number
France	UTE	1
Germany	VDE	1
Italy	IMQ	1
Japan	METI	3
The Netherlands	KEMA	1
Norway	NEMKO	1
The People's Republic of China	COC	5
South Korea	EK	4
Sweden	CEMKO	1
Switzerland	SEV	1
Taiwan	BSMI	4
The United Kingdom	BSI	1
The United States	UL	2

1. The flexible cord must be Type HO5VV-F, 3-conductor, 1.0-mm<sup>2</sup> conductor size. Power cord set fittings (appliance coupler and wall plug) must bear the certification mark of the agency responsible for evaluation in the country or region where it will be used.
2. The flexible cord must be Type SPT-3 or equivalent, No. 18 AWG, 3-conductor. The wall plug must be a two-pole grounding type with a NEMA 5-15P (15 A, 125 V) or NEMA 6-15P (15 A, 250 V) configuration.
3. The appliance coupler, flexible cord, and wall plug must bear a "T" mark and registration number in accordance with the Japanese Dentori Law. The flexible cord must be Type VCT or VCTF, 3-conductor, 1.00-mm<sup>2</sup> conductor size. The wall plug must be a two-pole grounding type with a Japanese Industrial Standard C8303 (7 A, 125 V) configuration.
4. The flexible cord must be Type RVV, 3-conductor, 0.75-mm<sup>2</sup> conductor size. Power cord set fittings (appliance coupler and wall plug) must bear the certification mark of the agency responsible for evaluation in the country or region where it will be used.
5. The flexible cord must be Type VCTF, 3-conductor, 0.75-mm<sup>2</sup> conductor size. Power cord set fittings (appliance coupler and wall plug) must bear the certification mark of the agency responsible for evaluation in the country or region where it will be used.

---

# 12 Recycling

When a non-rechargeable or rechargeable battery has reached the end of its useful life, do not dispose of the battery in general household waste. Follow the local laws and regulations in your area for battery disposal.

HP encourages customers to recycle used electronic hardware, HP original print cartridges, and rechargeable batteries. For more information about recycling programs, see the HP Web site at <http://www.hp.com/recycle>.

---

# Index

## A

- AC adapter, spare part number 38
- AC adapter, spare part numbers 35
- AC adapter/battery light 15, 18
- accessory battery connector 19
- antenna, locations 8
- audio, product description 4
- audio-in jack 17
- audio-out jack 17
- audio/USB board
  - removal 85
  - spare part number 26, 40, 85

## B

- base enclosure, spare part number 27, 40
- battery
  - removal 50
  - spare part numbers 28, 37, 38, 50
- battery bay 19
- battery release latch 19
- Blu-ray R/RE DVD±RW SuperMulti Double-Layer Drive
  - precautions 45
  - removal 54
  - spare part number 28, 35, 42, 54
- Blu-ray ROM DVD±RW SuperMulti Double-Layer Drive
  - precautions 45
  - removal 41, 54
  - spare part number 28, 35, 41, 54
- bottom components 19

## Bracket Kit

- components 31
- spare part number 31, 41
- button components 10
- buttons
  - optical drive eject 17
  - pointing stick 14
  - power 10
  - TouchPad 14
  - TouchPad on/off 14
  - volume mute 11
  - Windows key 12
  - wireless 11

## C

- Cable Kit
  - components 32
  - spare part number 32, 40
- cable lock, spare part numbers 35, 37, 38
- cables, service considerations 45
- caps lock light 13
- carrying case, spare part number 35, 38
- chipset, product description 1
- components
  - bottom 19
  - buttons 10
  - display 8
  - fingerprint reader 10
  - front 15
  - keys 12
  - left-side 16
  - lights 13
  - rear 18
  - right-side 17
  - speakers 10
  - TouchPad 14

## computer

- major components 23
- specifications 126
- connectors, service considerations 45

## D

- display switch 9
- display assembly
  - removal 96
  - spare part numbers 24, 42, 96
- display bezel
  - removal 100
  - spare part numbers 30, 41, 100
- display components 8
- display panel
  - product description 2
  - removal 101
  - spare part numbers 30, 42
- Display Panel Support Kit, spare part number 41
- docking connector 19
- drives, preventing damage 45
- Dual-Mode DisplayPort 16
- DVD-ROM Drive
  - precautions 45
  - removal 54
  - spare part number 28, 35, 42, 54
- DVD±RW SuperMulti Double-Layer Drive
  - precautions 45
  - removal 54
  - spare part number 28, 35, 42, 54

- E**
  - electrostatic discharge 46
  - equipment guidelines 48
  - esc key 12
  - Ethernet, product description 4
  - ExpressCard assembly
    - removal 81
    - spare part number 26, 40, 81
  - ExpressCard reader bezel,
    - illustrated 33
  - ExpressCard slot 16
  - external monitor port, location 17
- F**
  - fan/heat sink assembly
    - removal 90
    - spare part numbers 26, 40, 41, 90
  - fingerprint reader
    - component 10
    - location 11
  - fingerprint reader bezel,
    - illustrated 33
  - fingerprint reader blank cover,
    - illustrated 33
  - fingerprint reader board
    - removal 75
    - spare part number 26, 40, 75
  - fingerprint reader board bracket
    - illustrated 31
    - removal 75
  - flash cache, product description 2
  - fn key 12
  - front components 15
  - function button board
    - removal 77
    - spare part number 26, 40, 77
  - function keys 12
- G**
  - graphics board
    - removal 94
    - spare part numbers 27, 40, 42, 94
  - graphics, product description 1
  - grounding guidelines 46
  - guidelines
    - equipment 48
    - grounding 46
    - packaging 47
  - transporting 47
  - workstation 47
- H**
  - hard drive
    - precautions 45
    - product description 3
    - removal 52
    - spare part numbers 28, 34, 37, 38, 52
    - specifications 127
  - hard drive bracket
    - illustrated 34
    - removal 53
  - Hard Drive Hardware Kit
    - contents 34
    - spare part number 28, 34, 40
  - hard drive light 15
  - hard drive upgrade bay, spare part
    - number 28, 35, 41, 54
  - headphone jack 17
  - hinge
    - removal 102
    - spare part number 30, 42, 103
  - hinge cover
    - removal 97
    - spare part number 41, 97
  - Hinge Cover Kit, spare part
    - number 24
  - Hinge Kit, spare part number 42
- I**
  - integrated numeric keypad 12
- J**
  - jacks
    - audio-in 17
    - audio-out 17
    - headphone 17
    - microphone 17
- K**
  - key components 12
  - keyboard
    - product description 5
    - removal 62
    - spare part numbers 24, 38, 39, 40, 42, 43, 62
  - keys
    - esc 12
    - fn 12
    - function 12
    - integrated numeric keypad 12
    - num lk 12
- L**
  - left-side components 16
  - light components 13
  - lights
    - AC adapter/battery 15, 18
    - caps lock 13
    - hard drive 15
    - microphone mute 13
    - mute 13
    - num lock 13
    - power 13, 15
    - webcamera 8
    - wireless 13, 15, 18
- M**
  - mass storage device
    - illustrated 34
    - precautions 45
    - spare part numbers 34
  - memory card reader 17
  - memory module
    - product description 2
    - removal 61, 67
    - spare part numbers 26, 27, 37, 38, 61, 67
  - microphone
    - location 8
    - product description 4
  - microphone jack 17
  - microphone module
    - removal 102
    - spare part number 30, 41, 102
  - microphone mute light 13
  - model name 1
  - monitor port 17
  - mouse, spare part numbers 35, 37
  - mute light 13
- N**
  - network cable
    - illustrated 32
    - removal 109
  - num lk key 12
  - num lock light 13

- operating system, product description 6
  - optical drive
    - location 17
    - precautions 45
    - removal 54
    - spare part numbers 28, 35, 42, 54
  - optical drive eject button 17
- P**
  - packaging guidelines 47
  - plastic parts, service considerations 44
  - Plastics Kit
    - components 33
    - spare part number 33, 41
  - pointing device, product description 5
  - pointing stick 14
  - pointing stick button 14
  - ports
    - Dual-Mode DisplayPort 16
    - external monitor 17
    - monitor 17
    - product description 5
    - Thunderbolt 16
    - USB 2.0 16
    - USB 3.0 17, 18
    - USB 3.0 charging 16
  - power button 10
  - power button board
    - removal 79
    - spare part number 26, 40, 79
  - power connector 18
  - power connector cable
    - illustrated 32
    - removal 107
  - power cord
    - set requirements 146
    - spare part numbers 35, 37
  - power light 13, 15
  - power requirements, product description 5
  - processor
    - product description 1
    - removal 93
    - spare part numbers 26, 38, 42, 93
  - product description
    - audio 4
    - chipset 1
    - display panel 2
    - Ethernet 4
    - external media cards 4
    - flash cache 2
    - graphics 1
    - hard drive 3
    - keyboard 5
    - memory module 2
    - microphone 4
    - operating system 6
    - pointing device 5
    - ports 5
    - power requirements 5
    - processor 1
    - product name 1
    - security 6
    - serviceability 7
    - solid-state drive 2
    - Upgrade drive 3
    - video 4
    - wireless 4
  - product name 1
- R**
  - rear components 18
  - rear corner cover
    - removal 105, 109
    - spare part number 105, 110
  - removal/replacement procedures 49, 69
  - right-side components 17
  - RJ-45 cable
    - illustrated 32
    - removal 109
  - RTC battery
    - removal 69
    - spare part number 28, 41, 69
- S**
  - Screw Kit, spare part number 36, 40
  - SD card reader bezel, illustrated 33
  - security cable lock bracket
    - illustrated 31
    - removal 110
    - spare part number 110
  - security cable slot, location 16
  - security, product description 6
  - service considerations
    - cables 45
    - connectors 45
    - plastic parts 44
  - service cover
    - location 20
    - removal 51
    - spare part number 28, 40, 51
  - service cover release latch 19
  - service cover release lock 19
  - service tag 21
  - serviceability, product description 7
  - SIM slot 19
  - smart card reader 16
    - removal 83
    - spare part number 26, 42, 83
  - solid-state drive
    - precautions 45
    - product description 2
    - removal 58
    - spare part numbers 27, 34, 41, 42, 58
  - speaker components 10
  - Speaker Kit, spare part number 27
  - speakers
    - location 11
    - removal 89
    - spare part number 27, 41, 89
  - specifications
    - computer 126
    - hard drive 127
  - system board
    - removal 103
    - spare part numbers 27, 41, 103
  - system lens
    - illustrated 33
    - removal 81
- T**
  - Thunderbolt port 16
  - tools required 44
  - top cover
    - removal 71
    - spare part number 26, 40, 71
  - TouchPad button 14

- TouchPad components 14
- TouchPad on/off button 14
- TouchPad zone 14
- transporting guidelines 47

## U

- Upgrade drive, product
  - description 3
- USB 2.0 port 16
- USB 3.0 charging port 16
- USB 3.0 port 17, 18
- USB board
  - removal 87
  - spare part number 27, 41, 87

## V

- vents 16, 20
- video, product description 4
- volume mute button 11

## W

- webcamera 9
- webcamera light 8
- webcamera/microphone module
  - removal 102
  - spare part number 30, 41, 102
- Windows button 12
- wireless antenna, locations 8
- wireless button 11
- wireless light 13, 15, 18
- wireless, product description 4
- WLAN module
  - removal 59
  - spare part numbers 28, 37, 38, 59
- workstation guidelines 47
- WWAN module
  - removal 56
  - spare part numbers 28, 38, 56